



# OPERATING INSTRUCTIONS

EN

Translation of the Original

## ASM 340

Leak detector

---

## Disclaimer of liability

These operating instructions describe all models and variants of your product. Note that your product may not be equipped with all features described in this document. Pfeiffer Vacuum constantly adapts its products to the latest state of the art without prior notice. Please take into account that online operating instructions can deviate from the printed operating instructions supplied with your product.

Furthermore, Pfeiffer Vacuum assumes no responsibility or liability for damage resulting from the use of the product that contradicts its proper use or is explicitly defined as foreseeable misuse.

## Copyright

This document is the intellectual property of Pfeiffer Vacuum and all contents of this document are protected by copyright. They may not be copied, altered, reproduced or published without the prior written permission of Pfeiffer Vacuum.

We reserve the right to make changes to the technical data and information in this document.

# Table of contents

<b>1</b>	<b>About this manual</b>	<b>7</b>
1.1	Validity	7
	1.1.1 Products concerned	7
	1.1.2 Applicable documents	7
1.2	Target group	7
1.3	Conventions	8
	1.3.1 Pictographs	8
	1.3.2 Instructions in the text	8
	1.3.3 Labels	8
	1.3.4 Abbreviations	10
<b>2</b>	<b>Safety</b>	<b>11</b>
2.1	General safety information	11
	2.1.1 Safety instructions	11
	2.1.2 Precautions	12
2.2	Intended use	13
2.3	Foreseeable misuse	13
<b>3</b>	<b>Transportation and Storage</b>	<b>14</b>
3.1	Product receipt	14
3.2	Unpacking/Packing	14
3.3	Handling	16
3.4	Storage	17
<b>4</b>	<b>Product description</b>	<b>18</b>
4.1	Product identification	18
	4.1.1 Scope of delivery	18
	4.1.2 Variants	18
4.2	Connection interface	19
4.3	Control panel description	20
<b>5</b>	<b>Installation</b>	<b>21</b>
5.1	Detector installation	21
5.2	Storing the lifting handles	21
5.3	Filling with oil from the pump (Wet model)	22
5.4	Purge and inlet vent connection	24
	5.4.1 Standard equipment	24
	5.4.2 Connection of a neutral gas line (purge)	24
5.5	Connecting the exhaust	25
5.6	Electrical connection	25
5.7	Connecting the part/installation to be tested	26
5.8	Backing pump connection (Integrable model)	26
	5.8.1 Backing pump characteristics	26
	5.8.2 Connection of the backing pump	27
5.9	Connection of an external oil mist separator	28
<b>6</b>	<b>Commissioning</b>	<b>31</b>
6.1	Detector start-up	31
6.2	Test launched automatically upon start-up	31
6.3	Detector powering off	31
<b>7</b>	<b>Operation</b>	<b>32</b>
7.1	Use conditions	32
7.2	Prerequisites for optimizing use	32
7.3	Operation monitoring	32
7.4	Test Start/Stop	33
7.5	Calibration	34

7.5.1	Calibration type	34
7.5.2	Calibration in hard vacuum test mode with internal calibrated leak	35
7.5.3	Calibration in hard vacuum test mode with external calibrated leak	36
7.5.4	Calibration in sniffer test with external calibrated leak	37
7.5.5	Calibration in sniffer test on concentration	37
7.6	Zero Function	38
7.7	Touchscreen	38
7.7.1	Navigation	39
7.7.2	Main screen (Home)	40
7.7.3	Graph screen	41
7.7.4	Graph screen: graph parameters	44
7.7.5	Graph screen: recording	45
7.7.6	Graph screen: graph history	45
7.7.7	Graph screen: save and delete	45
7.7.8	Graph screen: display	46
7.7.9	Details of a measurement	48
7.7.10	Zoom function	48
7.7.11	Function key bar	49
<b>8</b>	<b>Settings menu</b>	<b>53</b>
8.1	Measurement menu	54
8.1.1	Tracer gas	54
8.1.2	Set points	55
8.1.3	Correction factor	57
8.1.4	Calibrated leak settings	59
8.1.5	Target value	60
8.2	Test menu	60
8.2.1	Test method	60
8.2.2	Test mode	61
8.2.3	Type of probe	61
8.2.4	Cycle end	62
8.2.5	Inlet vent	62
8.2.6	Memo Function	63
8.2.7	Zero activation	64
8.2.8	Regeneration	64
8.2.9	Massive Mode	65
8.2.10	Calibration check	65
8.2.11	Calibration function	66
8.2.12	Dynamic calibration	66
8.2.13	Purge valve	68
8.2.14	Start-up time delay	68
8.2.15	Crossover pressures	69
8.3	Configuration menu	69
8.3.1	Unit - Date - Time - Language	70
8.3.2	Sound volume	70
8.3.3	Function keys	71
8.3.4	Screen settings	72
8.3.5	Access - Password	73
8.4	Maintenance menu	75
8.4.1	History	75
8.4.2	Information	77
8.4.3	Last maintenance operations	79
8.4.4	Counters before next maintenance	79
8.4.5	Maintenance turbo pump and cell	80
8.4.6	Burn-in	80
8.4.7	Internal Pirani gauge calibration	81
8.4.8	External gauge	81
8.4.9	Saving/Loading of the detector parameters	82
8.5	File Manager menu	82



---

8.6	Advanced menu	84
	8.6.1 Input/Output	84
	8.6.2 Service	85
<b>9</b>	<b>Maintenance/Replacement</b>	<b>86</b>
<b>10</b>	<b>Accessories</b>	<b>87</b>
<b>11</b>	<b>Technical data and dimensions</b>	<b>88</b>
	11.1 General	88
	11.2 Technical characteristics	88
	11.3 Units of pressure	89
	11.4 Gas throughputs	89
	11.5 Dimensions	89
<b>12</b>	<b>Appendix</b>	<b>91</b>
	12.1 Tree diagram of the Settings menu	91
	<b>UL/CSA declaration of conformity</b>	<b>104</b>
	<b>Declaration of Conformity</b>	<b>105</b>
	<b>Declaration of incorporation of partly completed machinery</b>	<b>106</b>

## List of tables

Tbl. 1:	Units of pressure and their conversion	89
Tbl. 2:	Gas throughputs and their conversion	89
Tbl. 3:	Default settings: 'Measurement' menu	92
Tbl. 4:	Default settings: 'Test' menu	94
Tbl. 5:	Default settings: 'Configuration' menu	98
Tbl. 6:	Default settings: 'Maintenance' menu	101
Tbl. 7:	Default settings: 'File Manager' menu.	101
Tbl. 8:	Default settings: 'Advanced' menu	102
Tbl. 9:	Initial settings: Function key - [SWITCH SETPOINT]	103
Tbl. 10:	Initial settings: Graph screen - Graph parameters	103

# 1 About this manual



## IMPORTANT

Read carefully before use.  
Keep the manual for future consultation.

## 1.1 Validity

This operating instructions is a customer document of Pfeiffer Vacuum. The operating instructions describe the functions of the named product and provide the most important information for the safe use of the device. The description is written in accordance with the valid directives. The information in this operating instructions refers to the product's current development status. The document shall remain valid provided that the customer does not make any changes to the product.

### 1.1.1 Products concerned

This document applies to products with the following part numbers:

Part Number	Description
JSVA02AxMx9x	ASM 340 Wet (all models)
KSBA02AxMM9A	ASM 340 Dry (all models)
MSXA02AxMM9A	ASM 340 Integrable (all models)

### 1.1.2 Applicable documents

Document	Part Number
Maintenance instructions - ASM 340	128863M <sup>1)</sup>
Operating instructions - RS-232	122215 <sup>1)</sup>
Operating instructions - 37 pin I/O interface (Ethernet + USB)	128329 <sup>1)</sup>
Operating instructions - Profibus - Profinet - 15 pin I/O interface	128328 <sup>1)</sup>
Operating instructions - Communication interface for leak detectors	130417 <sup>1)</sup>
Operating instructions - ECB Wi-Fi external communication box	126169 <sup>1)</sup>
Operating instructions - HLT I/O compatibility module	122864 <sup>1)</sup>
Operating instructions - Standard sniffer probe	121780 <sup>1)</sup>
Operating Instructions - Smart sniffer probe	BG5268B <sup>1)</sup>
Operating instructions - Spray gun	121781 <sup>1)</sup>
Operating instructions - RC 10 remote control	124628 <sup>1)</sup>
UL/CSA Declaration of conformity	Included with these instructions
EC Declaration of conformity	Included with these instructions
EC Declaration of incorporation of partly completed machinery	Included with these instructions

<sup>1)</sup> also available at [www.pfeiffer-vacuum.com](http://www.pfeiffer-vacuum.com)

## 1.2 Target group

This user manual is intended for all persons in charge of transport, installation, commissioning/decommissioning, use, maintenance or storage of the product.

The work described in this document must only be carried out by persons with suitable technical training (specialized staff) or persons who have undergone Pfeiffer Vacuum training.

## 1.3 Conventions

### 1.3.1 Pictographs

Pictographs used in the document indicate useful information.



Note



Tip



Check a key point on the graphic.



Apply the stated tightening torque.



Respect the chronological order of operations and/or assembly/disassembly direction.



Correct, right choice.



Incorrect, wrong choice.

### 1.3.2 Instructions in the text

Usage instructions in the document follow a general structure that is complete in itself. The required action is indicated by an individual step or multi-part action steps.

#### Individual action step

A horizontal, solid triangle indicates the only step in an action.

- ▶ This is an individual action step.

#### Sequence of multi-part action steps







The numerical list indicates an action with multiple necessary steps.

1. Step 1
2. Step 2
3. ...

### 1.3.3 Labels

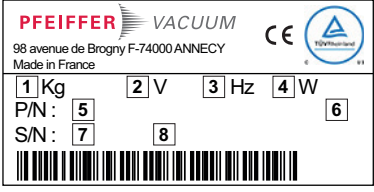
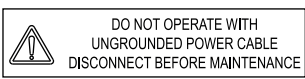
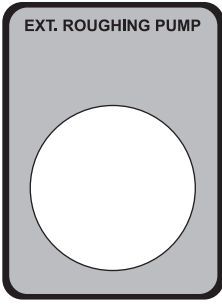
<b>I/O</b>	Main switch/Circuit breaker
<b>INPUTS/OUTPUTS</b>	Inputs/Outputs communication interface connector
<b>SERIAL</b>	9-pin D-Sub RS-232 serial link connector
<b>NETWORK</b>	Ethernet connector
<b>USB</b>	USB connector
<b>PROFIBUS DP</b>	9-pin D-Sub Profibus connector
<b>PROFINET IO</b>	RJ-45 Profinet connector

1		<p>This label indicates that the product has been certified compliant with quality control upon leaving the factory.</p>
2		<p>This label indicates that some of the internal parts are electrically live and could cause electrical shock in case of contact.</p> <ul style="list-style-type: none"> <li>• Disconnect the main power supply cable from the product before removing the cover.</li> </ul>

3	<p><b>NOTICE</b> PUMP IS SHIPPED WITHOUT OIL INSTALLED Consult operating manual <b>CAUTION</b></p>	<p>Wet Model only This label indicates that the backing pump is drained at the factory. The oil must be filled before the detector is put into service for the first time.</p>																				
4		<p>This label indicates that the product must be handled using the devices identified by this label.</p> <ul style="list-style-type: none"> <li>Comply with the rules for moving the equipment, taking weight and dimensions into account.</li> </ul>																				
5		<p>This label indicates that the product is subject to regulations for the treatment of electrical and electronic equipment waste (refer to the EC declaration of conformity for the product).</p>																				
6		<p>Product rating plate.</p> <table border="1" data-bbox="576 633 1257 734"> <tr> <td>1</td> <td>Weight</td> <td></td> <td>5</td> <td>Part number</td> </tr> <tr> <td>2</td> <td>Use voltage</td> <td></td> <td>6</td> <td>Description</td> </tr> <tr> <td>3</td> <td>Use frequency</td> <td></td> <td>7</td> <td>Serial number</td> </tr> <tr> <td>4</td> <td>Maximum power consumption</td> <td></td> <td>8</td> <td>Date of manufacture</td> </tr> </table>	1	Weight		5	Part number	2	Use voltage		6	Description	3	Use frequency		7	Serial number	4	Maximum power consumption		8	Date of manufacture
1	Weight		5	Part number																		
2	Use voltage		6	Description																		
3	Use frequency		7	Serial number																		
4	Maximum power consumption		8	Date of manufacture																		
7		<p>This label indicates that some of the internal parts are electrically live and could cause electrical shock in case of contact.</p> <ul style="list-style-type: none"> <li>Do not use the product if the main power supply cable is not earthed.</li> <li>Disconnect the main power supply cable from the product before servicing the product.</li> </ul>																				
8		<p>Integrable model only This label indicates that the connection hole for the external backing pump is on the rear side.</p>																				
-		<p>This label guarantees to the user that the product packaging has not been opened since leaving the factory.</p>																				
-		<p>This label indicates that the product has been customized at the customer's request.</p>																				
-		<p>This label indicates the grounding point on the product.</p>																				
-	<table border="1" data-bbox="180 1451 486 1608"> <tr> <td>Pu_GL : 1</td> <td>Pu_N : 1</td> </tr> <tr> <td>Mu_GL : 12856</td> <td>Mu_N : 31</td> </tr> <tr> <td>Mu_Cal : 1</td> <td>Mu_LDS : 1800</td> </tr> </table>	Pu_GL : 1	Pu_N : 1	Mu_GL : 12856	Mu_N : 31	Mu_Cal : 1	Mu_LDS : 1800	<p>For service centers use only (Example)</p>														
Pu_GL : 1	Pu_N : 1																					
Mu_GL : 12856	Mu_N : 31																					
Mu_Cal : 1	Mu_LDS : 1800																					
-	<p><b>HLD1302577 - RS232</b> Bluetooth MAC address XXXXXX / None Network MAC address xx:xx:xx:xx:xx:xx / None</p>	<p>This label indicates the MAC address for the options installed in the product. (Example)</p>																				
-	<p>DD-MM-YY<sup>④</sup> <b>Factory Firmware /Logiciel usine</b> L0232 V3302 E17D L0264 V3200 FD87E7D L0285 V3200 8C9D ① ② ③</p>	<p>This label provides information regarding firmware installed in the product. (Example)</p> <table border="1" data-bbox="576 1865 1134 1921"> <tr> <td>1</td> <td>Firmware name</td> <td></td> <td>3</td> <td>Firmware checksum</td> </tr> <tr> <td>2</td> <td>Firmware version</td> <td></td> <td>4</td> <td>Publication date</td> </tr> </table>	1	Firmware name		3	Firmware checksum	2	Firmware version		4	Publication date										
1	Firmware name		3	Firmware checksum																		
2	Firmware version		4	Publication date																		

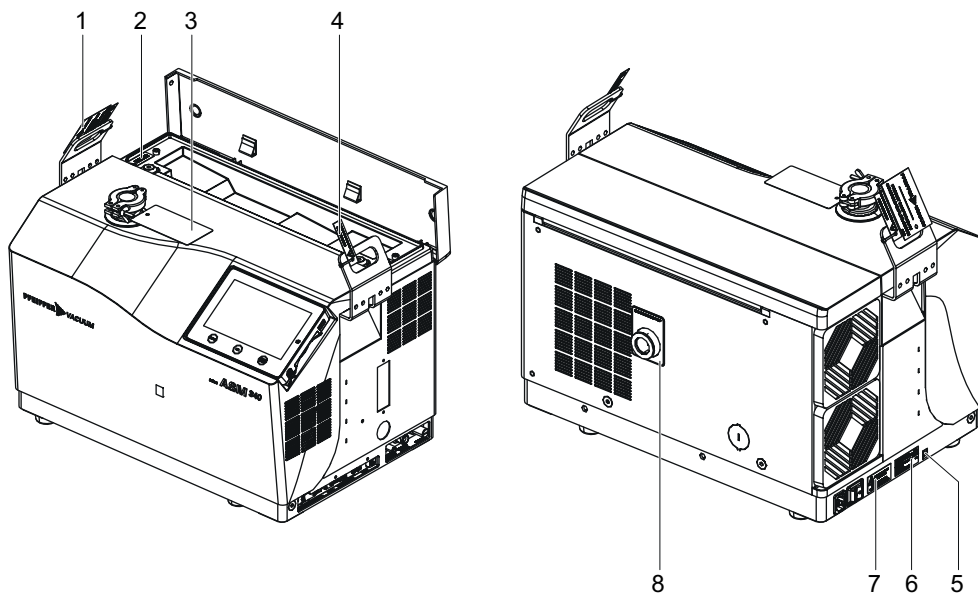

### 1.3.4 Abbreviations

I/O	Input/Output
$^4\text{He}$	Helium 4
$\text{H}_2$	Hydrogen
[XXXXXX]	Control panel menus and settings
	Example: <b>[Measurement] [Tracer gas]</b> to select the tracer gas used for the test.

## 2 Safety

### 2.1 General safety information

The following 4 risk levels and 1 information level are taken into account in this document.

#### **DANGER**

##### **Immediately pending danger**

Indicates an immediately pending danger that will result in death or serious injury if not observed.

- ▶ Instructions to avoid the danger situation

#### **WARNING**

##### **Potential pending danger**

Indicates a pending danger that could result in death or serious injury if not observed.

- ▶ Instructions to avoid the danger situation

#### **CAUTION**

##### **Potential pending danger**

Indicates a pending danger that could result in minor injuries if not observed.

- ▶ Instructions to avoid the danger situation

#### **NOTICE**

##### **Danger of damage to property**

Is used to highlight actions that are not associated with personal injury.

- ▶ Instructions to avoid damage to property



Notes, tips or examples indicate important information about the product or about this document.

#### 2.1.1 Safety instructions

All safety instructions in this document are based on the results of the risk assessment carried out in accordance with Low-Voltage Directive 2014/35/EU regarding electrical safety. Where applicable, all life cycle phases of the product were taken into account.

#### **WARNING**

##### **Risk of electric shock due to non-compliant electrical installations**

This product uses mains voltage for its electrical supply. Non-compliant electrical installations or installations not done to professional standards may endanger the user's life.

- ▶ Only qualified technicians trained in the relevant electrical safety and EMC regulations are authorized to work on the electrical installation.
- ▶ This product must not be modified or converted arbitrarily.

#### **WARNING**

##### **Risk of electric shock in case of contact with products that are not electrically isolated**

When powering off \_mains switch to **O\_**, certain components located between the mains connection and the circuit breaker will still contain an electric charge (live). There is a risk of electric shock in case of contact.

- ▶ Make sure that the mains connection is always visible and accessible so that it can be unplugged at any time.
- ▶ Disconnect the mains cable from the electrical network before working on the product.
- ▶ Wait 5 minutes after power-off before working on the product and/or removing the cover(s).

**⚠ WARNING**

**Risk of serious injury due to falling objects**

When transporting parts/components and during product maintenance, there is a danger of injury caused by loads slipping or falling.

- ▶ Carry small and medium-size components with both hands.
- ▶ Transport components that weigh more than 20 kg using suitable lifting gear.
- ▶ Wear safety shoes with steel toes in accordance with directive EN 347.

**⚠ WARNING**

**Health risk related to residual traces on the parts tested**

A leak detection operation must be carried out under environmental conditions that do not present any risks to the operator and the equipment. The user and/or integrator of the product are fully responsible for the operational safety conditions of the equipment.

- ▶ Do not test parts or equipment with traces of harsh, chemical, corrosive, inflammable, reactive, toxic, or explosive substances, nor condensable vapors, even in small amounts.
- ▶ Apply the relevant safety instructions in accordance with local regulations.

**⚠ WARNING**

**Risk of injury from contact with pressurized neutral gas**

The product uses a pressurized inert gas (e.g. nitrogen) as the purge gas. Installations that do not comply with or are not configured according to professional standards can endanger the user's life.

- ▶ Install a manual valve on the circuit at a distance of 3 m from the product, so that the neutral gas supply can be locked out.
- ▶ Observe the recommended supply pressure.
- ▶ Always lock out and disconnect the neutral gas circuit before working on the product.
- ▶ Regularly check the condition of the pipework and supply circuit connections.

**⚠ CAUTION**

**Risk of pinching when handling the storage box cover**

- ▶ Be careful not to leave your fingers under the cover when closing.

**⚠ CAUTION**

**Risk of crushing related to product tilting**

Although the product fully complies with EU safety regulations, there is a risk of tilting when the product is not correctly installed or used.

- ▶ Place the product on a flat, hard floor.
- ▶ Keep the product on its 4 feet.

**2.1.2 Precautions**

**i**

**Duty to provide information on potential dangers**

The product holder or user is obliged to make all operating personnel aware of dangers posed by this product.

Every person who is involved in the installation, operation or maintenance of the product must read, understand and adhere to the safety-related parts of this document.

**i**

**Obligation to provide personal protective equipment**

The operators or employers are obliged to provide the user of the product with the necessary personal protective equipment (PPE).

Persons responsible for installing, operating and repairing the product must wear PPE for safety.





#### **Infringement of conformity due to modifications to the product**

The Declaration of Conformity from the manufacturer is no longer valid if the operator changes the original product or installs additional equipment.

- Following the installation into a system, the operator is required to check and re-evaluate the conformity of the overall system in the context of the relevant European Directives, before commissioning that system.



#### **Installation and use of the accessories**

The products can be fitted with special accessories.

The installation, use and refurbishment of the connected accessories are described in detail in the respective operating instructions.

- Only use original accessories.
- Accessory part numbers (see chapter “Accessories”).

Only qualified personnel trained in safety regulations (EMC, electrical safety, chemical pollution) are authorized to carry out the installation and maintenance described in this manual. Our service centers can provide the necessary training.

- ▶ Do not remove the blanked-off flange from the inlet port while the product is not in use.
- ▶ Do not expose any part of the human body to the vacuum.
- ▶ Follow the safety and accident prevention requirements.
- ▶ Regularly check compliance with all precautionary measurements.
- ▶ Do not turn on the product if the cover is not in place.
- ▶ Do not move the product while it is in use (product powered on).

## **2.2 Intended use**

The leak detector is designed to detect and/or quantify a possible installation or component leak by searching for the presence of a tracer gas in the pumped gases.

Only the tracer gases identified in this manual may be used.

The product may be used in an industrial environment.

## **2.3 Foreseeable misuse**

Misuse of the product will render the warranty and any claims void. Any use, whether intended or not, that diverges from the uses already mentioned will be treated as non-compliant; this includes but is not limited to:

- use of a tracer gas with a hydrogen concentration greater than 5%,
- testing parts that are soiled or that have traces of water, vapors, paint, adhesive, detergent or rinsing products,
- pumping of liquids,
- pumping of dust or solids,
- pumping of corrosive, explosive, aggressive or flammable fluids,
- pumping of reactive, chemical or toxic fluids,
- pumping of condensable vapors,
- operation in potentially explosive areas,
- product movement during its operation,
- use of accessories or spare parts, which are not named in this manual,
- use of accessories or spare parts, which are not sold by the manufacturer.

The product is not designed to carry people or loads and is not for use as a seat, stepladder or any other similar purpose.

## 3 Transportation and Storage

### 3.1 Product receipt



#### Condition of the delivery

- Check that the product has not been damaged during transport.
- If the product is damaged, take the necessary measures with the carrier **and** notify the manufacturer.

- ▶ Keep the product in its original packaging so it stays as clean as it was when dispatched by us: only unpack the product once it has arrived at the location where it will be used.
- ▶ Keep the blank-off flange on the inlet port (inlet) when the product is not in use.



Keep the packaging (recyclable materials) in case the product needs to be transported or stored.

### 3.2 Unpacking/Packing

#### ⚠ CAUTION

##### Risk of crushing related to product tilting

Although the product fully complies with EU safety regulations, there is a risk of tilting when the product is not correctly installed or used.

- ▶ Place the product on a flat, hard floor.
- ▶ Keep the product on its 4 feet.

#### Unpacking

- ▶ Use a lifting device suitable for the product's weight to lift the product.
- ▶ Use a 3-strand strap with the following characteristics:
  - Length for each strand: > 500 mm
  - Load per strand: > 100 kg

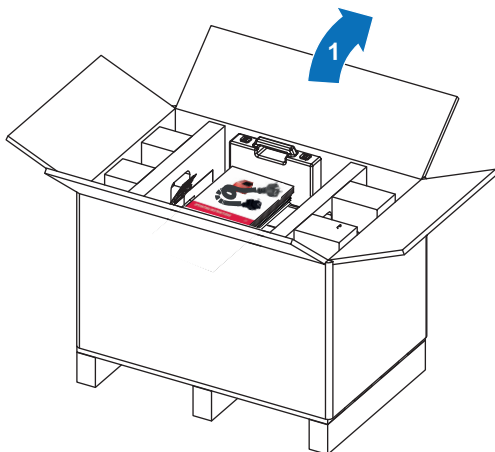

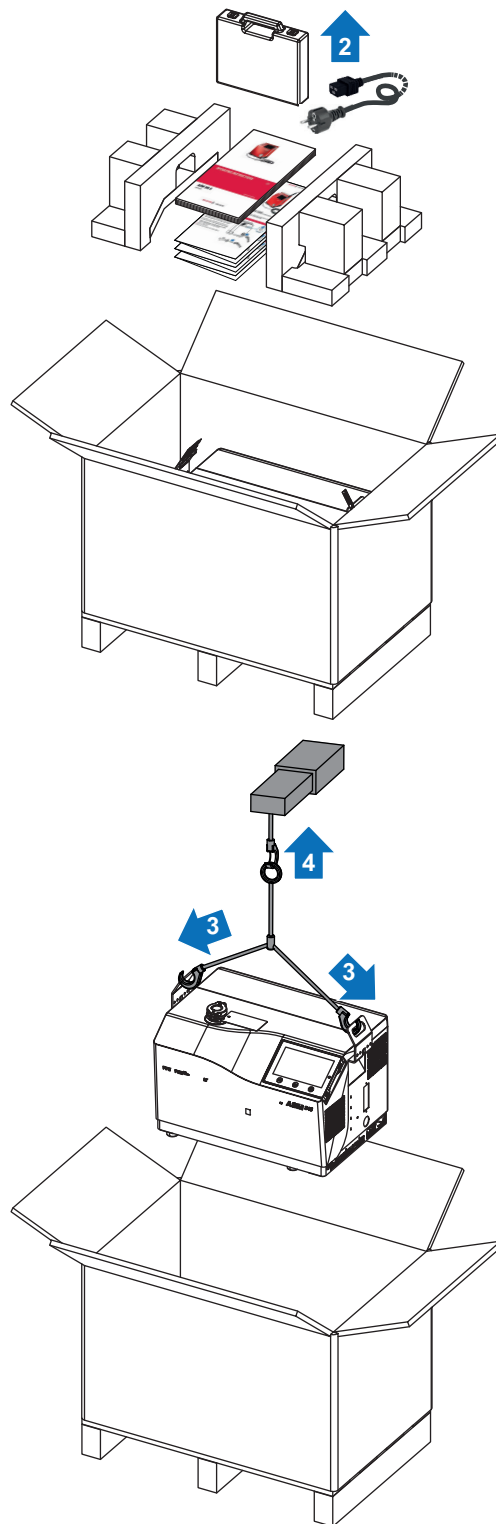

### Packaging

When sending the detector to a service center, keep the accessories delivered with the detector. Do not return them with the product.

- Proceed in reverse order of unpacking.

### 3.3 Handling

#### **⚠ WARNING**

##### **Risk of crushing during product handling**

Given the weight of the product, there is a risk of crushing during handling operations. Under no circumstances shall the manufacturer be liable if the following instructions are not followed:

- ▶ Only qualified staff trained in handling heavy objects are authorized to handle the product.
- ▶ The lifting devices provided **must be used** for the product and the procedures set out in this document must be followed.

#### **⚠ WARNING**

##### **Risk of serious injury due to falling objects**

When transporting parts/components and during product maintenance, there is a danger of injury caused by loads slipping or falling.

- ▶ Carry small and medium-size components with both hands.
- ▶ Transport components that weigh more than 20 kg using suitable lifting gear.
- ▶ Wear safety shoes with steel toes in accordance with directive EN 347.

#### **NOTICE**

##### **Damage to the equipment if a detector is handled while switched on**

When switched off (main switch/circuit breaker at **O**), some components remain temporarily switched on. There is a risk of electric shock in case of contact.

If it is necessary to move or work on the product, the user must first make sure that the detector is fully shut down. There is a risk of damage to some of the detector's components.

- ▶ Make sure that the mains connection is always visible and accessible so that it can be unplugged at any time.
- ▶ Unplug the power cable.
- ▶ Wait 5 minutes after power-off before working on the product.

A cart has been specially designed to handle the leak detector (see chapter "Accessories").

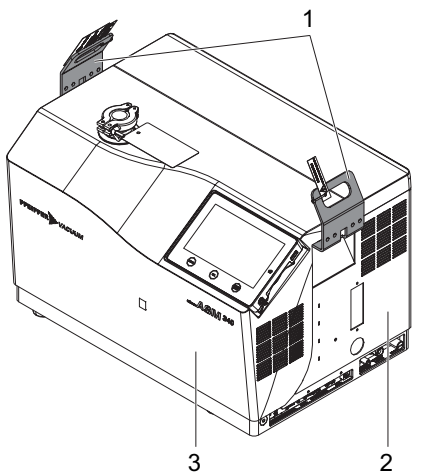

- 1 Handle
- 2 Rear cover
- 3 Front cover

- ▶ Make sure the covers are securely fastened before handling the product after removing/assembling the covers for a maintenance operation.
  - The front cover hides 3 rear cover fixing screws (out of the 5 screws in total): make sure that these 3 screws are present and correctly tightened.
  - Make sure that all the fixing screws for the covers on the detector frame (5 screws for the rear cover and 4 for the front cover) are in place and properly tightened.
- ▶ Move the product by grasping it by the 2 handles, for 2 people, or by using a lifting device (see chapter "Unpacking/Packing").

## 3.4 Storage



Pfeiffer Vacuum recommends storing the products in their original transport packaging.

### New product storage

- ▶ Leave the product in its packaging.
- ▶ Leave the blanked-off flange in place on each port.
- ▶ Store the module in a clean and dry environment according to the permitted temperature conditions (see chapter "Technical data").
- ▶ Beyond 3 months, factors such as temperature, humidity, salt in the air, etc. could damage some components (elastomers, lubricants, etc.). If this happens, contact your service center.

### Extended storage

With this procedure, the detector remains under vacuum, reducing the degassing time spent when it is switched on again.

1. Install the blank-off flange on the inlet port.
2. In the '**Test**' menu, check:
  - that the 'hard vacuum' test method is selected,
  - that the most sensitive test mode is selected,
  - that the inlet vent valve is set to 'Operator'.
3. Start the test by pressing the **START/STOP** button.
  - Wait until the leak detector reaches the most sensitive test mode.
4. Make sure that the inlet vent is disable.
5. Stop the detector (set main switch/circuit breaker to **O**).
6. Wait for the control panel turn off.
7. Unplug the main power supply cable.

## 4 Product description

### 4.1 Product identification

To correctly identify the product when communicating with our service center, always have the information from the product rating plate available (see chapter "Labels").

#### 4.1.1 Scope of delivery

- 1 leak detector
- 1 set of documentation (USB stick, operating instructions, simplified memos for the detector and the RS-232 serial link)
- 1 main power supply cable for Europe (France/Germany) and/or 1 power cable for US
- 2 lifting handles installed on the product
- 1 calibration certificate for the internal calibrated leak
- 1 quality control certificate for the product
- 1 Quality Control label
- 1 funnel (Wet model)
- 1 oil can (Wet model)
- 1 draining connector (Wet model)
- 1 maintenance kit
- 1 DN 25 ISO-KF plastic blanking plate (Integrable model)
- 1 protective cover
- 1 15-pin or 37-pin D-Sub male connector cover (depending on option)
- 1 15-pin or 37-pin D-Sub connector (depending on option)

#### 4.1.2 Variants

The ASM 340 leak detectors are particularly suitable in Industry for vacuum and sniffer leak detection, in various applications from maintenance to small production applications.

Easy operation, robustness, ultra fast response time, are among the outstanding features of these compact multipurpose units.

- **ASM 340, conventional pumping**  
Using a 15 m<sup>3</sup>/h rotary vane pump, this detector delivers unmatched performance in a compact design.  
It will be named Wet Model in this manual.
- **ASM 340, dry pumping**  
Available with diaphragm pump, it is the perfect unit for clean applications where no pollution can be tolerated.  
It will be named Dry Model in this manual.
- **ASM 340, without backing pumping**  
For greater versatility, it enables the backing pump to be sized according to the need for roughing.  
It will be named Integrable Model in this manual.

## 4.2 Connection interface

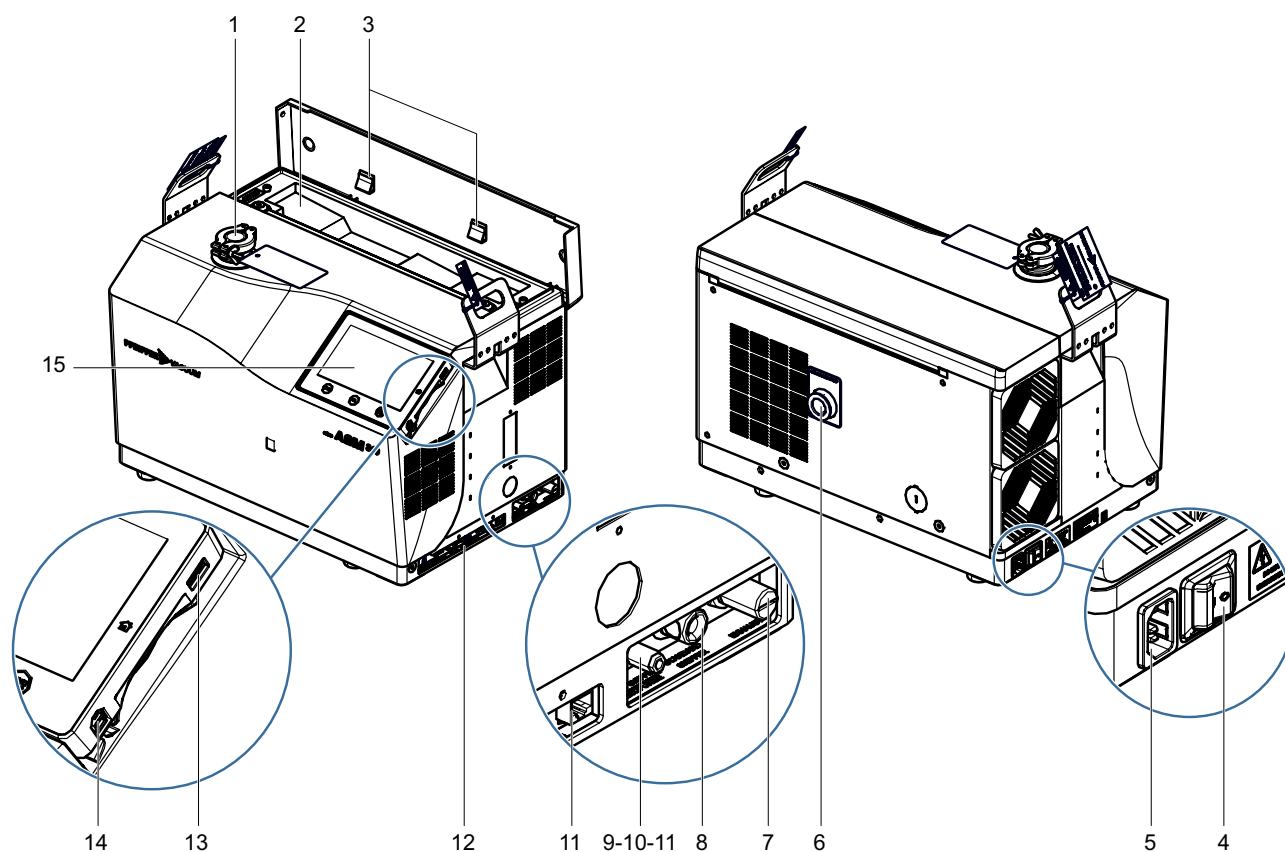

- |   |  |    |   |
|---|--|----|---|
| 1 | Detector inlet port (inlet)  | 9  | Inlet vent connector ( <b>SMART SNIFFER/VENT/PURGE</b> ) <sup>1)</sup>                |
| 2 | Storage box (maximum permitted weight in the box: 5 kg)                    | 10 | Purge inlet connector (neutral gas) ( <b>SMART SNIFFER/VENT/PURGE</b> ) <sup>1)</sup> |
| 3 | Fasteners for storing the Memo   | 11 | Smart sniffer probe connector ( <b>SMART SNIFFER/VENT/PURGE</b> ) <sup>1)</sup>       |
| 4 | Main switch/Circuit breaker ( <b>I/O</b> )                                 | 12 | Communication interface according to order configuration (example)                    |
| 5 | Power supply   | 13 | Connector for USB stick (at the user's expense)                                       |
| 6 | Backing pump connection (Integrable model only)                            | 14 | RC 10 remote control connector <sup>1)</sup>  |
| 7 | Exhaust for backing pump ( <b>EXHAUST</b> ) (Wet and Dry models only)      | 15 | Control panel   |
| 8 | Standard sniffer probe connector ( <b>STANDARD SNIFFER</b> ) <sup>1)</sup> |    |   |

1) Accessory (at the customer's expense)

### 4.3 Control panel description

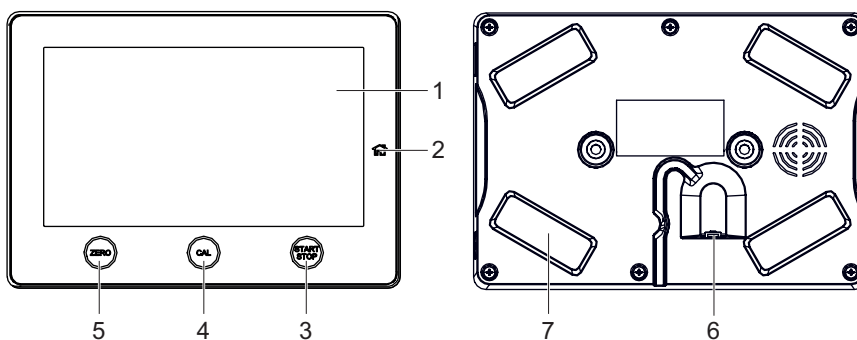

- 1 Touchscreen
- 2 Main screen access button
- 3 **START/STOP** button  
Test Start/Stop
- 4 **CAL** button  
Internal calibration, external calibration or calibration check is launched depending on the setting (see chapter "Calibration type").
- 5 **ZERO** button  
Autozero.
- 6 Detector connection cable connector
- 7 Fixing magnet (x4)



## 5 Installation

### 5.1 Detector installation

#### **⚠ WARNING**

##### **Risk of serious injury due to falling objects**

When transporting parts/components and during product maintenance, there is a danger of injury caused by loads slipping or falling.

- ▶ Carry small and medium-size components with both hands.
- ▶ Transport components that weigh more than 20 kg using suitable lifting gear.
- ▶ Wear safety shoes with steel toes in accordance with directive EN 347.

#### **⚠ CAUTION**

##### **Risk of crushing related to product tilting**

Although the product fully complies with EU safety regulations, there is a risk of tilting when the product is not correctly installed or used.

- ▶ Place the product on a flat, hard floor.
- ▶ Keep the product on its 4 feet.

#### **NOTICE**

##### **Leak detector ventilation**

In cases of poor ventilation, there is a risk of deterioration of the detector's internal components by heating.

- ▶ Comply with the ambient operating temperature.
- ▶ Do not obstruct the ventilation grids.
- ▶ Ventilation grids should be cleaned regularly.
- ▶ Leave a free space of at least 10 cm all around the leak detector.
- ▶ Store nothing under the detector.

The inlet pressure must be no higher than atmospheric pressure. Pressure that is too high can damage the detector.

The detector's performance depends on the type of accessories used and on the quality of the mechanical connections.

- ▶ Comply with these recommendations to optimize measurement (see chapter "Pre-requisites for optimizing use").
- ▶ Choose the location for set up according to the dimensions of the detector (see chapter "Dimensions").
- ▶ Handle the detector using the handling device (see chapter "Handling").
- ▶ The leak detector must be installed on a horizontal flat surface.
- ▶ Make sure that the test area is not polluted by the tracer gas (ventilated room).
- ▶ Test that the entire line is completely sealed when the detector is attached to the pumping circuit, to ensure that the connections are correct (pump, pipes, valves, etc.).
- ▶ When assembling the vacuum circuit, use accessories to shut off the product and make maintenance easier (inlet shut off valves, purge systems, etc.).

### 5.2 Storing the lifting handles

When the detector is installed, the handles can be removed and stored at the back of the detector.

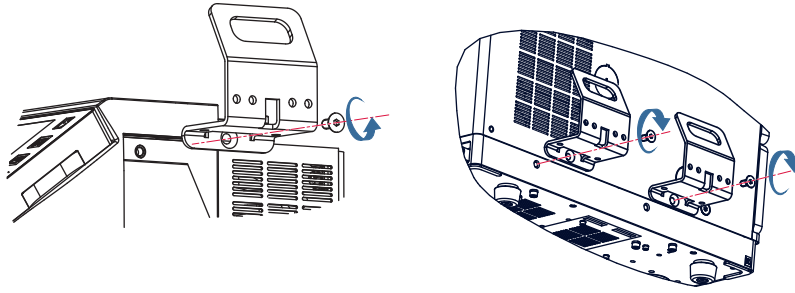

### 5.3 Filling with oil from the pump (Wet model)

**⚠ DANGER**

**Risk of poisoning in case of contact with the operating fluid**

There is a potential poisoning danger if the operating fluid comes into contact with the skin or the vapor is inhaled.

- ▶ Wear protective gear such as gloves, glasses and a mask when handling the oil.

**NOTICE**

**The product may be damaged if an unauthorized operating fluid is used**

The pumps are tested at the factory using Pfeiffer Vacuum oil. Using any other oil may adversely affect the pump and its performance.

- ▶ It is **essential** that the oil recommended by the manufacturer is used.



**Safety data sheets**

You can obtain the safety data sheets for operating fluids from Pfeiffer Vacuum on request, or from the [Pfeiffer Vacuum Download Center](#).

**Tools/Consumables**

- 1 funnel supplied with the product
- 1 oil can (1 liter)

**Prerequisite**

- ▶ Power off the leak detector (see chapter “Powering Off”).

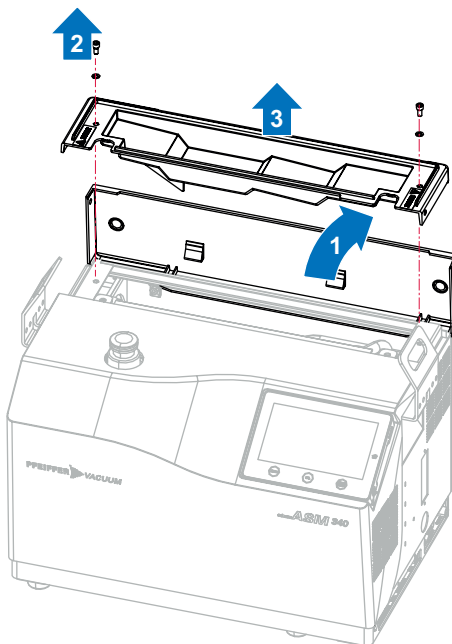

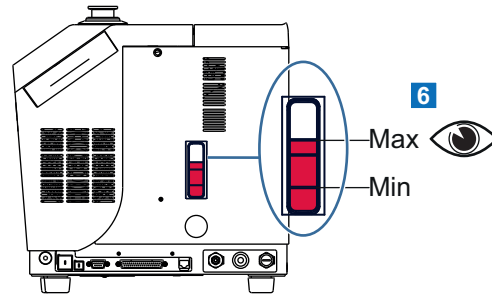
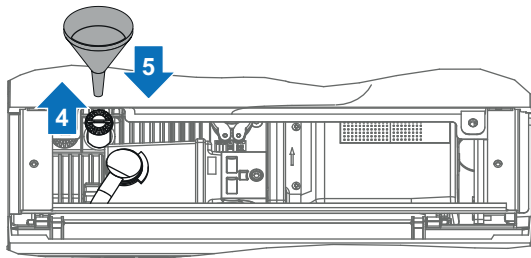

 Oil filling is carried out until the maximum level is reached.

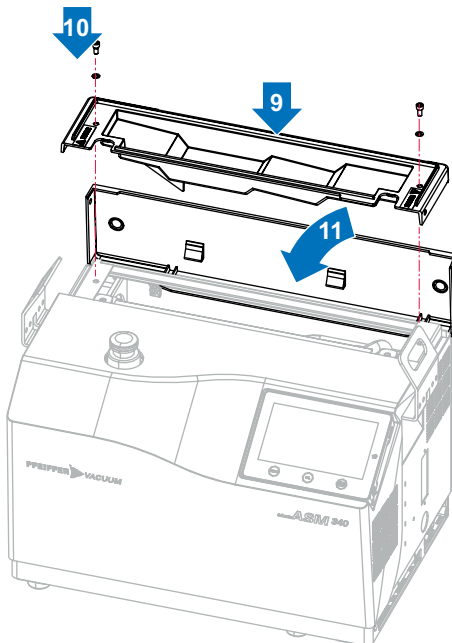
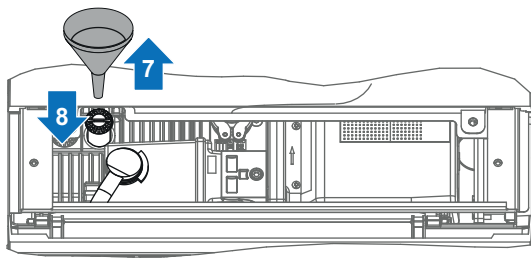

## 5.4 Purge and inlet vent connection

### 5.4.1 Standard equipment

#### NOTICE

##### Risk of pollution from tracer gas

The leak detector should not be used in an environment with a high concentration of tracer gas. The tracer gas risks polluting the leak detector.

The manufacturer cannot be held responsible for the product's pollution with tracer gas.

- ▶ Ensure good ventilation in the area where the detector will be used.

#### NOTICE

##### Incorrect use of purge

A leak detection operation should be carried out on parts or equipment that contain any trace of substances that are aggressive, chemical, corrosive, inflammable, reactive, toxic, explosive, or on condensable vapors, even in small quantities.

- ▶ Do not use the purge to dilute these hazardous products. This is not its purpose.

The detector is equipped with an inlet vent optimizing the detector's operation.

- If no inlet vent system is connected, the inlet vent is connected to the ambient air.
- The inlet vent status (opened or closed) depends on the parameters set by the user (see the chapter "Inlet vent").

### 5.4.2 Connection of a neutral gas line (purge)

The use of a neutral gas (nitrogen, for example) allows for the leak detector background to be reduced.

The purge maintains a flow of air inside the detector.

The neutral gas should be different than the tracer gas used.

Wet Model: the purge system line is always closed and cannot be set by the operator.

Dry and Integrable models: it is possible to connect the detector to a neutral gas line (purge) (at the customer's expense). The purge can be automatic/open/closed depending on the setting.

In addition to the purge, activating the 'Pollution' function is recommended (see chapter "Pollution function").

#### ⚠ WARNING

##### Risk of injury from contact with pressurized neutral gas

The product uses a pressurized inert gas (e.g. nitrogen) as the purge gas. Installations that do not comply with or are not configured according to professional standards can endanger the user's life.

- ▶ Install a manual valve on the circuit at a distance of 3 m from the product, so that the neutral gas supply can be locked out.
- ▶ Observe the recommended supply pressure.
- ▶ Always lock out and disconnect the neutral gas circuit before working on the product.
- ▶ Regularly check the condition of the pipework and supply circuit connections.

#### NOTICE

##### Incorrect use of purge

A leak detection operation should be carried out on parts or equipment that contain any trace of substances that are aggressive, chemical, corrosive, inflammable, reactive, toxic, explosive, or on condensable vapors, even in small quantities.

- ▶ Do not use the purge to dilute these hazardous products. This is not its purpose.

##### Flow

To guarantee best performance, the neutral gas supply must be dry and filtered, with the following characteristics:

- relative excess pressure: 200 hPa
- flow rate: 50 sccm (if pressure = 1 bar (absolute) at the inlet)

**Use pressure**

If the neutral gas pressure is too high, the inlet vent valve may remain closed.

- 0 to 0.3 bar relative ( $\approx$  0 to 4.5 psig)
- 1 to 1.3 bar absolute ( $\approx$  14.5 to 19 psig)

**Procedure**

- ▶ Connect the neutral gas pipework to the inlet vent and purge connector (see chapter "Connection interface").

## 5.5 Connecting the exhaust

### NOTICE

#### Risk of deterioration due to overpressure at exhaust

Too much pressure at the detector's exhaust risks damaging the detector.

- ▶ Ensure that the customer application exhaust line is always under slightly negative pressure.
- ▶ Make sure the detector's exhaust pressure does not exceed 200 hPa (relative).

**Dry model**

The detector's exhaust is equipped with an external filter.

The detector exhaust filter (**EXHAUST**) must never be removed.

The detector exhaust (**EXHAUST**) must never be obstructed.

- ▶ Clean the filter regularly.

**Wet model**

### NOTICE

#### High-pressure pumping - Wet model only

- ▶ Connect the exhaust of the detector to an exhaust duct or pipe.  
Connection: 1/8 gas

The detector's primary pump is equipped with an internal oil mist eliminator.

The detector exhaust (**EXHAUST**) must never be obstructed.

The operator can connect an external eliminator instead of this internal eliminator.

- ▶ Install the connection tubing designed for this purpose and available as an accessory (see chapter "Connecting an external oil mist separator").

If degassing the customer application, you are advised to connect the detector exhaust to an exhaust line (at the customer's charge), ensuring that the detector is always used in compliance with the recommendations given.

## 5.6 Electrical connection

### ⚠ WARNING

#### Risk of electric shock due to non-compliant electrical installations

This product uses mains voltage for its electrical supply. Non-compliant electrical installations or installations not done to professional standards may endanger the user's life.

- ▶ Only qualified technicians trained in the relevant electrical safety and EMC regulations are authorized to work on the electrical installation.
- ▶ This product must not be modified or converted arbitrarily.

**NOTICE**

**Risk of electromagnetic disturbance**

Voltages and currents can induce a multitude of electromagnetic fields and interference signals. Installations that do not comply with the EMC regulations can interfere with other equipment and the environment in general.

- ▶ Use shielded cables and connections for the interfaces in interference-prone environments.

**Electrical safety**

The leak detector is Class 1 equipment and therefore must be earthed.

- ▶ Connect the power supply to the connector using the power cable supplied with the detector (see chapter “Connection interface”).
- ▶ See chapter “Technical characteristics”.

## 5.7 Connecting the part/installation to be tested

**NOTICE**

**Risk of deterioration of parts or installations**

There is a risk of deterioration for parts or installations connected to the leak detector vacuum circuit.

- ▶ Make sure that the parts or installations connected to the detector’s pump inlet withstand a negative pressure of  $1 \cdot 10^3$  hPa in relation to the atmospheric pressure.

- The maximum permitted weight at the detector’s inlet must be no more than 15 kg and the maximum torque must be 10 N · m.
- The inlet pressure must be no higher than atmospheric pressure. Pressure that is too high can damage the product.
- The detector’s performance depends on the type of accessories used and on the quality of the mechanical connections.
- When assembling the vacuum circuit, use accessories to shut off the product and make maintenance easier (inlet shut off valves, purge systems, etc.).
- Comply with these recommendations to optimize measurement (see chapter “Pre-requisites for optimizing use”).

**Connection**

- ▶ Remove the blanked-off flange that covers the detector’s inlet port and save it for reuse during storage or transport.
- ▶ Use pipes with a diameter equal to the diameter of the detector’s inlet. The pipes should be as short as possible and completely sealed.
- ▶ Connect the part or the installation to be tested using the connection accessories available in the product catalogue.
- ▶ Connect the part or the installation to be tested using the flexible pipeworks. Never use rigid or flexible plastic pipework (compressed air style tube).

## 5.8 Backing pump connection (Integrable model)

### 5.8.1 Backing pump characteristics

Characteristics	
Backing pump	Wet or Dry pump
Connection	DN 25 ISO-KF Hose with a maximum length of 2 m between the detector and the backing pump
Ultimate vacuum	< 1 hPa ( $5 \cdot 10^{-2}$ hPa recommended)

Characteristics	
Min flow	1 m <sup>3</sup> /h If using in sniffer with the Smart probe, minimum flow rate = 3 m <sup>3</sup> /h
Max flow	100 m <sup>3</sup> /h A higher flow rate will not improve the performance of the leak detector + backing pump assembly.

## 5.8.2 Connection of the backing pump

The leak detector must be connected to a backing pump before being switched on.

2 DN 25 ISO-KF connections are available to connect the backing pump.

- 1 connection at the rear (configuration on delivery)
- 1 connection under the frame

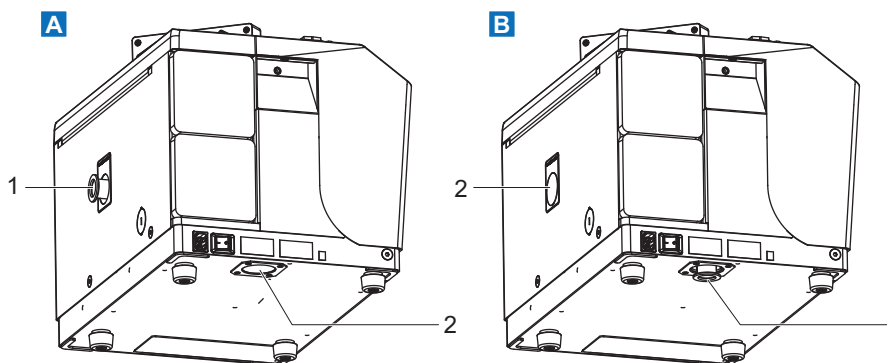

- |                          |  |
|--------------------------|--|
| A Connection at the rear | 1 DN 25 ISO-KF connection tubing                                   |
| B Connection underneath  | 2 DN 25 ISO-KF plastic blanking plate (supplied with the detector) |
|                          | 2 Filler cap   |

### Backing pump connection under the frame

#### NOTICE

##### Using an external backing pump

It is the user's responsibility to protect the detector from any contamination or deterioration that may be caused by the connected external backing pump (particles, backscattering of oil in the detector, for example).

- Any contamination or deterioration of the detector due to the connected external backing pump will not be recognized by the manufacturer under warranty.

1. Remove the front cover (see chapter "Disassembly/reassembly of the front cover" in the maintenance instructions).
2. Remove the rear cover (see chapter "Disassembly/reassembly of the rear cover" in the maintenance instructions).
3. Remove the filler cap, which is clipped on, from the frame ([A]).
4. Remove the 4 M6x16 fixing screws and their washers from the connection tubing ([A]).
5. Release the connection tubing and replace the 4 M6x16 fixing screws and their washers ([A]).
6. Remove the 4 M6x12 fixing screws and their washers ([A]).
7. Place the connection tubing in its housing on the frame and secure it with the 4 M6x12 fixing screws and their washers ([B]).
8. Refit the covers.
9. Clip the filler cap into the opening of the rear cover ([C]).
10. Fit the DN 25 ISO-KF plastic blanking plate (supplied with the detector) onto the connection tubing ([C]):
  - as long as the detector is not connected to an external backing pump
  - any time the detector is dispatched.

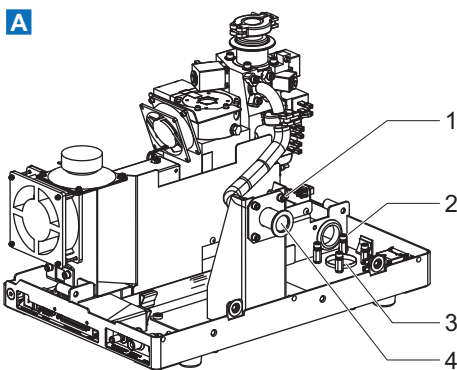

- 1 4 M6x12 fixing screws and washers (rear connection)
- 2 4 M6x12 fixing screws and washers (connection underneath)
- 3 Filler cap
- 4 DN 25 ISO-KF connection tubing

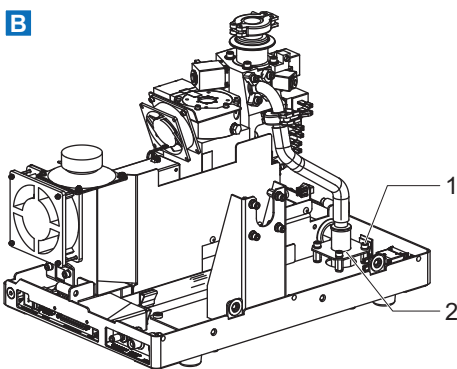

- 1 4 M6x12 fixing screws and washers (connection underneath)
- 2 DN 25 ISO-KF connection tubing

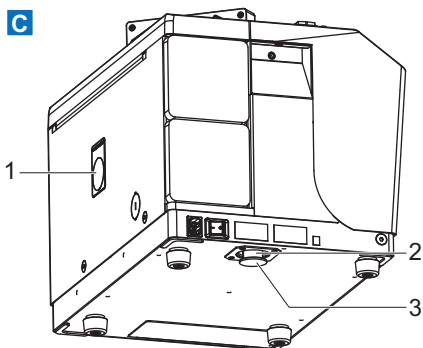

- 1 Filler cap
- 2 DN 25 ISO-KF connection tubing
- 3 DN 25 ISO-KF plastic blanking plate (supplied with the detector)



**Connection tubing under the frame**

When dispatching the detector in this configuration, never use a metal blanking plate and its clamp: only a plastic blanking plate must be used.

### 5.9 Connection of an external oil mist separator

The user has the option of connecting an external oil mist separator to replace the internal oil mist separator installed in the detector.

This modification requires the installation of a DN 25 ISO-KF connector to connect the external oil mist separator.

The external oil mist separator and the DN 25 ISO-KF connector are the responsibility of the customer (see chapter "Accessories").



**Prerequisites**

1. Remove the front cover (see chapter "Disassembly/reassembly of the front cover" in the maintenance instructions).
2. Remove the rear cover (see chapter "Disassembly/reassembly of the rear cover" in the maintenance instructions).
3. Remove the internal oil separator (see chapter "Replacing the internal oil mist separator" in the maintenance instructions).

**Procedure**

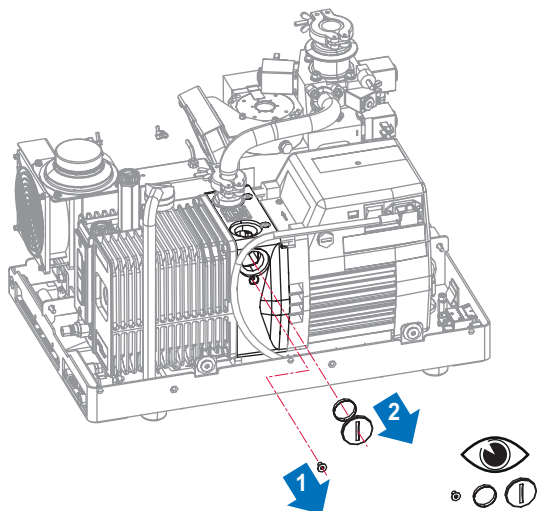

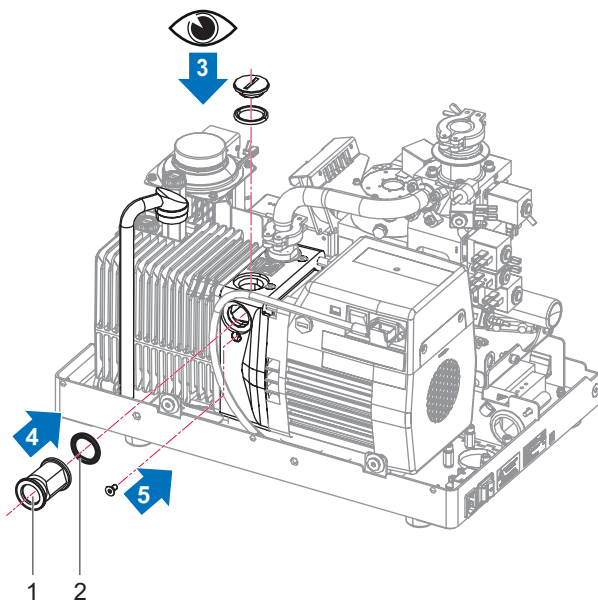

 The 3 components are reused in the following steps.

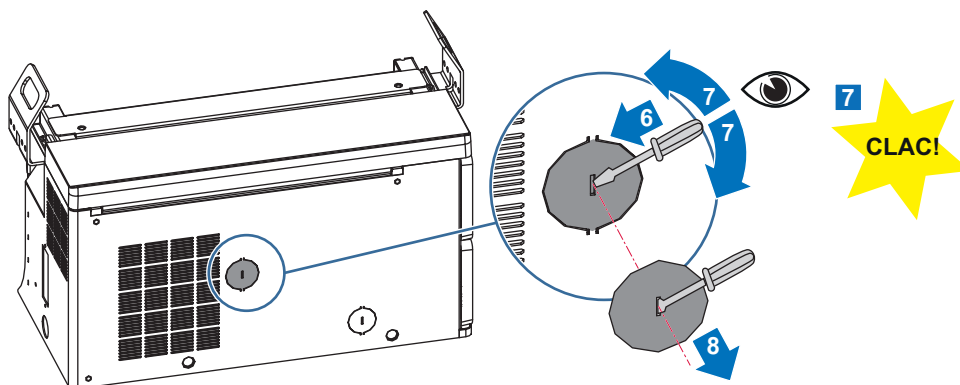

 The cap must be screwed on fully.

- |                          |   |
|--------------------------|---|
| 1 Connector DN 25 ISO-KF | 2 Seal DN 25 ISO-KF (supplied with the connector) |
|--------------------------|---|



 The back and forth movements of the screwdriver make it possible to release the cover by breaking the 2 points that are fastened to the cover.

## 6 Commissioning

### 6.1 Detector start-up

1. Connect the main power supply cable.
2. Set the main switch/circuit breaker to **I**.
3. For first start-up: set the language, unit, date and time (the user can modify these settings at a later time).
4. Wait for the detector to enter "Stand-by" mode.

#### Start-up after an extended shutdown

If the detector has been stored or has not been used, start-up time is longer than if it is in regular use.



After a shutdown of the detector of more than 3 months, it is advisable to start up the detector 24 hours before its use.

### 6.2 Test launched automatically upon start-up

This function is used to automatically start the first test after the detector start-up phase.

If the function is enabled, the 1<sup>st</sup> test starts automatically as soon as the detector start-up phase is completed. Subsequent tests are launched by the user.

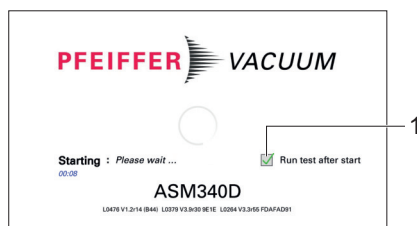

- 1 Check box for the 'Run Test after start?' message

1. Ensure that the inlet is connected before starting the function.
2. During the detector start-up phase, check  to enable the function.
  - The question will be asked each time the leak detector is switched on. The last selection made is not saved.

### 6.3 Detector powering off

1. Set the switch/circuit breaker to **O**.
2. Wait for the control panel screen to turn off completely before working on the product, removing the cover and/or moving it.
3. Disconnect the mains power cable.

#### Pump stop due to power failure

When there is a mains power failure, the detector shuts down: it switches on again automatically when power is restored.

## 7 Operation

### 7.1 Use conditions

#### **WARNING**

##### **Risk of injury due to the use of hydrogen as tracer gas**

Hydrogen can be used as a tracer gas for leak detection. Depending on its concentration, in the worst scenario, there may be a risk of explosion.

- ▶ Never use a tracer gas with a hydrogen content greater than 5%.
- ▶ Use hydrogenated nitrogen as a tracer gas: mix of 95% N<sub>2</sub> and 5% H<sub>2</sub>.

#### **NOTICE**

##### **Leak detector ventilation**

In cases of poor ventilation, there is a risk of deterioration of the detector's internal components by heating.

- ▶ Comply with the ambient operating temperature.
- ▶ Do not obstruct the ventilation grids.
- ▶ Ventilation grids should be cleaned regularly.
- ▶ Leave a free space of at least 10 cm all around the leak detector.
- ▶ Store nothing under the detector.

#### **NOTICE**

##### **Risk of deterioration from solid particles**

The tested applications may generate solid particles.

It is recommended in this case to protect the detector inlet (inlet port).

- ▶ Install a filter at the detector inlet (see chapter "Accessories").

Environmental conditions: see chapter "Technical characteristics".



### 7.2 Prerequisites for optimizing use

Before each commissioning, and in order to optimize the use of the leak detector, the user must observe the following points.

- ▶ Become familiar with the safety instructions.
- ▶ Check that all the connections are correct.
- ▶ Do not move the product as soon as the product is switched on.
- ▶ Make sure that the leak detector is in an environment free of tracer gas.
- ▶ No message should be displayed.
  - No **[i Next]** pictogram displayed on the main screen.
  - If the pictograph is displayed, read the message and address it.
- ▶ Perform leak detector calibration.
- ▶ Test only clean, dry parts/installations with no trace of water, vapor, paint, detergent or rinsing products.
- ▶ Check that the connected part/installation is impervious to tracer gas.

### 7.3 Operation monitoring

During operation, the user is notified of an incident on the detector control panel.

Type of fault	Control panel	
Warning		Press on <b>[i Next]</b> to display the fault.
Error		Message display. Press on <b>[i Next]</b> to display the fault.
Critical error		Display of "Critical error - E244" message. Contact our service center.

## 7.4 Test Start/Stop

### Prerequisites

See chapter "Start-up of the detector"

### Test method

The test method is chosen depending on the part to be tested.

For more information about leak detection test methods, see **Leak detector compendium** on the [www.pfeiffer-vacuum.com](http://www.pfeiffer-vacuum.com) website.

There are 2 possible test methods:

- Hard Vacuum
- Sniffer

### Hard vacuum test

The test can also be started using a remote control (accessory): see the remote control operating instructions.

1. Select the 'hard Vacuum' test method (see chapter "Test method").
2. Select the test mode (see chapter "Test mode").
3. Set the reject point and warning set point if necessary (see chapter "Set points").
4. Put the detector on 'Stand-by' mode.
  - In 'Stand-by' mode, the leak rate displayed corresponds to the detector's background.
5. Carry out air inlet by pressing the **[VENT]** function key.
6. Prepare the part/installation to be tested (see chapter "Part/installation connection to be tested").
  - Spray method
    - Connect the part/installation to be tested to the leak detector inlet port.
    - Evacuate the air from the part/installation to be tested.
  - Bombing method
    - Place the part to be tested in a pressurization chamber with the tracer gas.
    - Remove the part to be tested from the chamber and put it in the test chamber connected to the leak detector inlet port.
7. Start the test by pressing the **START/STOP** button.
  - Spray method
    - Spray the tracer gas on the points on the part that are likely to leak.
8. The various test steps are displayed.

When the detector has reached the most sensitive test mode, wait for the measurement to stabilize: the measurement displayed corresponds to the measured leak rate.
9. Stop the test by pressing the **START/STOP** button.

### Sniffer test

1. Prepare the part/installation to be tested.
2. Select the 'sniffer' test method (see chapter "Test method").
3. Depending on the model of the detector, select the model of the sniffer probe used (see chapter "Type of probe").
4. Set the reject point and warning set point if necessary (see chapter "Set points").
5. Put the detector on 'Stand-by' mode.
6. Connect the sniffer probe (accessory).
7. Start the test by pressing the **START/STOP** button.

8. Then run the sniffer probe slowly over the areas of the part to be tested that may leak: the leak rate displayed varies when a leak is detected (quantitative value of the measured leak rate).
9. Stop the test by pressing the **START/STOP** button.

## 7.5 Calibration

Calibration is used to ensure that the leak detector is correctly adjusted to detect the tracer gas selected and display the correct leak rate.

A calibrated leak is used to calibrate the leak detector.

By default, internal leak is selected to allow for a rapid calibration of the leak detector. It is also possible to calibrate the leak detector using an external leak.

The leak detector should be calibrated with a calibrated leak of the same type as the tracer gas used.



### Detector calibration

20 minutes after switching it on, the detector suggests that the user perform a calibration. For correct use of the detector and to optimize the accuracy of the measurement, **this calibration must be performed.**

It is recommended to perform a calibration:

- at least once a day,
- for intense operation: start calibration at the beginning of each work session (e.g. work in shifts, every 8 hours),
- if it is uncertain whether the detector is working properly.

### Internal calibrated leak

The internal calibrated leak is specifically designed for the leak detector. It is composed of:

- a reservoir filled with <sup>4</sup>He tracer gas (no internal calibration with other tracer gases),
- a temperature sensor (to take into account the effect of temperature on the leak rate),
- an integrated diaphragm (to calibrate the leak rate),
- an identification label (identical to the identification label of an external calibrated leak).

The calibrated leak is supplied with a calibration certificate.



Use a calibrated leak in the range of  $\approx 10^{-7}$  mbar · l/s ( $\approx 10^{-8}$  Pa · m<sup>3</sup>/s).



In the case of intensive use of the detector, a spare internal calibrated leak is recommended. By default, the detector can be calibrated with an external calibrated leak.

### External calibrated leak

The operator must use a calibrated leak containing the tracer gas selected (<sup>4</sup>He, Mass 3 or H<sub>2</sub>).

There are several types of external calibrated leaks, with or without reservoir, with or without valve, covering several ranges of leaks.

The manufacturer does not provide calibrated leaks in Mass 3 and H<sub>2</sub>.



The choice of external calibrated leak depends on application requirements: use a calibrated leak from the same leak rate range as the leak to be measured.

### 7.5.1 Calibration type

The user assigns a calibration type to the **CAL** button.

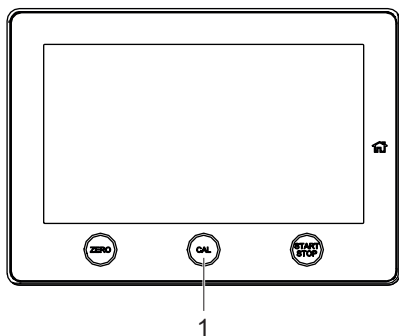

1 CAL button

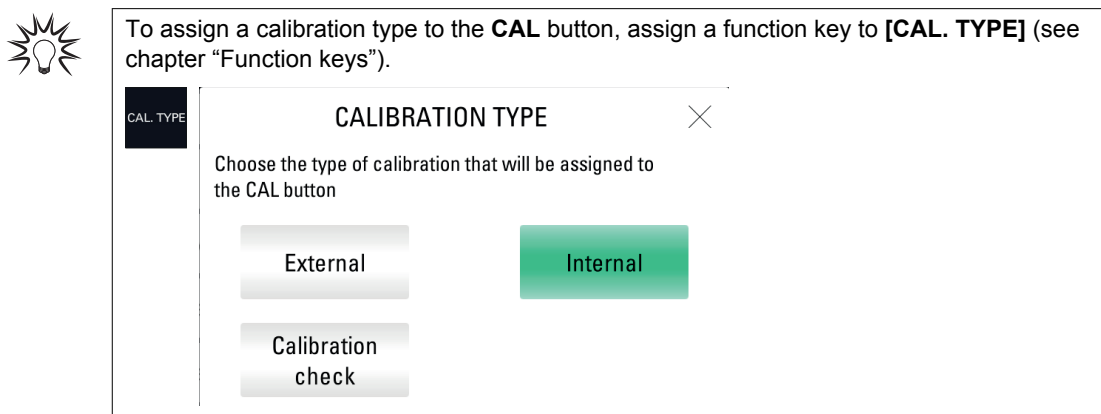

**Procedure**

1. Press the [CAL. TYPE] function key.
2. Select the calibration type to assign to the [CAL. TYPE] function key.
  - Internal calibration: calibration of the leak detector with the internal calibrated leak (factory configuration)
  - External calibration: calibration of the leak detector with an external calibrated leak
  - Calibration check (see chapter “Calibration check”)
3. Confirm the selection [X].

The calibration type assigned to the CAL button is displayed on the main screen.

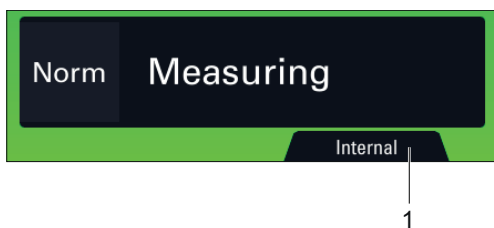

1 Calibration type assigned to the CAL button

Test method	Calibration type selected	Main screen display
Hard vacuum test	Internal calibration	Internal
	External calibration	External
	Calibration check	Check
Sniffer test	Concentration	Concentration
	External calibration	Sniffer

**7.5.2 Calibration in hard vacuum test mode with internal calibrated leak**

**Internal calibrated leak**

The internal calibrated leak is specifically designed for the leak detector. It is composed of:

- a reservoir filled with  $^4\text{He}$  tracer gas (no internal calibration with other tracer gases),
- a temperature sensor (to take into account the effect of temperature on the leak rate),
- an integrated diaphragm (to calibrate the leak rate),
- an identification label (identical to the identification label of an external calibrated leak).

The calibrated leak is supplied with a calibration certificate.



Use a calibrated leak in the range of  $\approx 10^{-7}$  mbar · l/s ( $\approx 10^{-8}$  Pa · m<sup>3</sup>/s).



In the case of intensive use of the detector, a spare internal calibrated leak is recommended. By default, the detector can be calibrated with an external calibrated leak.

### Calibration

Calibration can be performed when the detector is in 'Stand-by' mode.

1. Configure the following settings:
  - test method: hard vacuum (see chapter "Test method")
  - calibration type: internal (see "Calibration type")
  - type of calibrated leak: internal (see chapter "Calibrated leak")
  - calibration: operator (see chapter "Calibration function")
2. Check the leak settings (leak rate corrected for temperature and time as needed) (see chapter "Calibrated leak").
3. Press the **CAL** button to start a calibration.

To stop a calibration, press the **CAL** button 3 times in under 5 seconds.

## 7.5.3 Calibration in hard vacuum test mode with external calibrated leak

### External calibrated leak

The operator must use a calibrated leak containing the tracer gas selected ( $^4\text{He}$ , Mass 3 or  $\text{H}_2$ ).

There are several types of external calibrated leaks, with or without reservoir, with or without valve, covering several ranges of leaks.

The manufacturer does not provide calibrated leaks in Mass 3 and  $\text{H}_2$ .



The choice of external calibrated leak depends on application requirements: use a calibrated leak from the same leak rate range as the leak to be measured.



Calibration with an external calibrated leak is advised when the reject point is far from the internal calibrated leak value.

### Calibration

To stop a calibration at any time, press the **CAL** button 3 times in under 5 seconds.

1. Configure the following settings:
  - test method: hard vacuum (see chapter "Test method")
  - calibration type: external (see "Calibration type")
  - type of calibrated leak: external (see chapter "Calibrated leak")
  - calibration: operator (see chapter "Calibration function")
2. Verify the setting for the external calibrated leak used (see chapter "Calibrated leak").
3. As needed, correct the parameters of the external calibrated leak used (see the label for the calibrated leak or the calibration certificate).
4. Select the tracer gas for the external calibrated leak (see chapter "Calibrated leak").
5. Check that the detector is in 'Stand-by' mode.
6. Carry out air inlet by pressing the **[VENT]** function key.
7. Check that the detector is in 'Stand-by' mode.
8. Press the **CAL** button to start a calibration.
9. Follow the instructions given by the leak detector.
  - Press **[Next]** to move to the next step.

At the end of the calibration, the detector returns to 'Stand-by' mode.



## 7.5.4 Calibration in sniffer test with external calibrated leak

### External calibrated leak

The operator must use a calibrated leak containing the tracer gas selected ( $^4\text{He}$ , Mass 3 or  $\text{H}_2$ ).

There are several types of external calibrated leaks, with or without reservoir, with or without valve, covering several ranges of leaks.

The manufacturer does not provide calibrated leaks in Mass 3 and  $\text{H}_2$ .



The choice of external calibrated leak depends on application requirements: use a calibrated leak from the same leak rate range as the leak to be measured.

### Calibration

1. Configure the following settings:
  - test method: sniffer (see chapter "Test method")
  - calibration type: external (see "Calibration type")
  - type of calibrated leak: external (see chapter "Calibrated leak")
  - calibration: operator (see chapter "Calibration function")
2. Select the tracer gas for the external calibrated leak (see chapter "Tracer gas").
3. Verify the setting for the external calibrated leak used (see chapter "Calibrated leak").
  - Correct the temperature, month and year if necessary.
4. Press the **CAL** button to start a calibration.
5. Follow the instructions given by the leak detector.
  - Press **[Next]** to move to the next step.

To stop a calibration, press the **CAL** button 3 times in under 5 seconds.

### Adaptor for external calibrated leaks

A DN 16 ISO-KF or DN 25 ISO-KF adaptor is used to calibrate the detector with an external calibrated leak in sniffer test mode (with Standard sniffer probe only).

Adaptor part number (see chapter "Accessories").

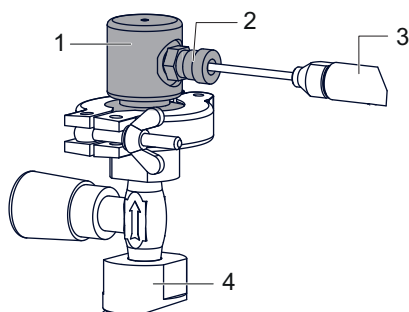

- |  |                   |
|--|-------------------|
| 1 DN 16 ISO-KF or DN 25 ISO-KF adaptor | 3 Sniffer probe   |
| 2 Fixing screws                        | 4 Calibrated leak |

1. Attach the adaptor to the external calibrated leak used for the calibration with a centering ring and a clamp.
2. Press the **CAL** button to start a calibration.
3. Place the sniffer probe in the calibration port.
4. Tighten the fixing screw.
5. Follow the instructions given by the leak detector.
  - Press **[Next]** to move to the next step.
6. Loosen the fixing screw.
7. Remove the sniffer probe from the calibration port.
8. Follow the instructions given by the leak detector.
  - Press **[Next]** to move to the next step.
9. Wait 10 s (at least) before reading the leak rate.

## 7.5.5 Calibration in sniffer test on concentration

Concentration = volume at atmospheric pressure filled with a gas mixture for which the tracer gas content is known.

Calibration on concentration can only be carried out in sniffer test mode, with the detector in 'Stand-by' mode.

Before starting this function, make sure that the leak detector is in an environment free of tracer gas pollution.

1. Configure the following settings:
  - test method: sniffer (see chapter "Test method")
  - calibration type: Concentration (see "Calibration type")
  - calibration: calibration (see "Calibration function")
2. Select the tracer gas for the concentration (see chapter "Tracer gas").
3. Press the **CAL** button to start a calibration.
4. Follow the instructions given by the leak detector.
  - Press **[Next]** to move to the next step.

At the end of the calibration, the detector returns to 'Stand-by' mode.

## 7.6 Zero Function

The zero function helps the user to identify very small leak rate variations in the surrounding background noise or to dilate small measured leak rate fluctuations on the analog display.

### Zeroing

Configuration (see chapter "Zero activation").

Over time, there may be a deviation in the leak rate display. Zeroing must be performed regularly in the following cases:

- when the detector's background value increases,
- before performing a precise measurement.

1. Press the **ZERO** button.

## 7.7 Touchscreen

The touch screen is interfaced with the detector and is used to:

- display information about the test,
- access the available functions,
- set the detector's parameters.

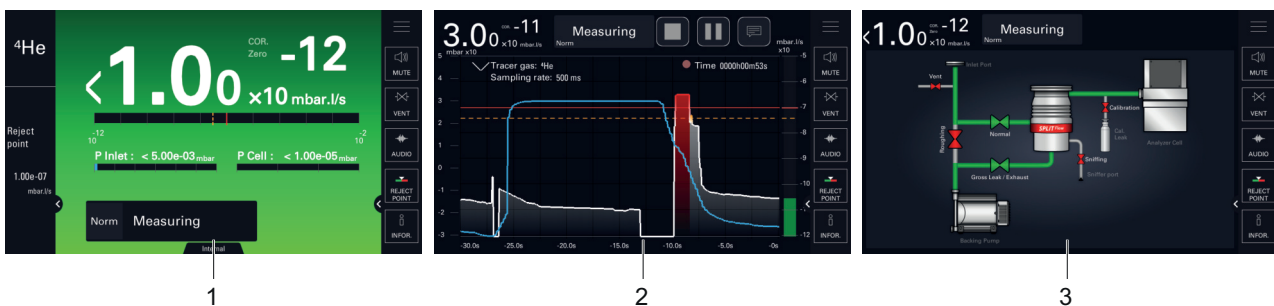

- 1 Main screen **[Home]**: Information about the current test
- 2 Graph screen: Monitoring and recording of the leak rate

- 3 Synoptic: Schematic diagram of the detector and the status of the valves

The contents of the screens are provided as an example: depending on the detector settings, the display may be different.

- ▶ Remove the film that protects the touch screen upon delivery.
- ▶ Use the touch screen manually without using hard objects such as pens, screwdrivers, etc.
- ▶ Use the RS-232 to control/set the detector if the touch screen is out of service (broken screen).

### Screenshot



To take a screenshot, press the **[SCREEN SHOT]** function key (see chapter “Function keys”).



- The screenshots are always saved in the internal memory.
- Name of screenshots: ScreenYYYYMMDD\_HHMMSS (Example: Screen20210203\_143302).

## 7.7.1 Navigation

### Symbols

Symbol	Description
	Available on the control panel Return to the main screen from any menu <b>[Home]</b> in the instructions
	Return to previous menu
	Access to a sub-menu
 	Access secured with password <ul style="list-style-type: none"> <li>• Red closed padlock: access prohibited (password access)</li> <li>• Green open padlock: access permitted</li> </ul>
 	Enabling slider <ul style="list-style-type: none"> <li>• Black slider: function not enabled</li> <li>• Green slider: function enabled</li> </ul>
	Action button (access to a setting, function, etc.)
	Navigation tools <ul style="list-style-type: none"> <li>• &lt;&lt; &gt;&gt;: access to the first/last item</li> <li>• &lt; &gt;: access to the previous/next item</li> </ul> <b>[ &lt;&lt; &gt;&gt; ] [ &lt; &gt; ]</b> in the instructions
	Error message
	Critical error message
	Access error/warning message <b>[i Next]</b> in the instructions
	Setting tool <ul style="list-style-type: none"> <li>• The green slider indicates the set value.</li> <li>• To increase/decrease this value, press on the right/left of the cursor.</li> </ul>
	Access the Settings menu
	Return to home page <b>[X]</b> in the instructions
	Saving the change made <b>[✓]</b> in the instructions
	Display/Hide an area
	Cursor for screen navigation (horizontal or vertical)

Access to the main/graph/synoptic screen



The synoptic can be hidden or shown (see chapter "Screen setting").

Access to the synoptic and function keys

- ▶ The synoptic can be hidden or shown (see chapter "Screen setting").
- ▶ The function keys can be displayed (enabled) or hidden (disabled) (see chapter "Function keys").

7.7.2 Main screen (Home)

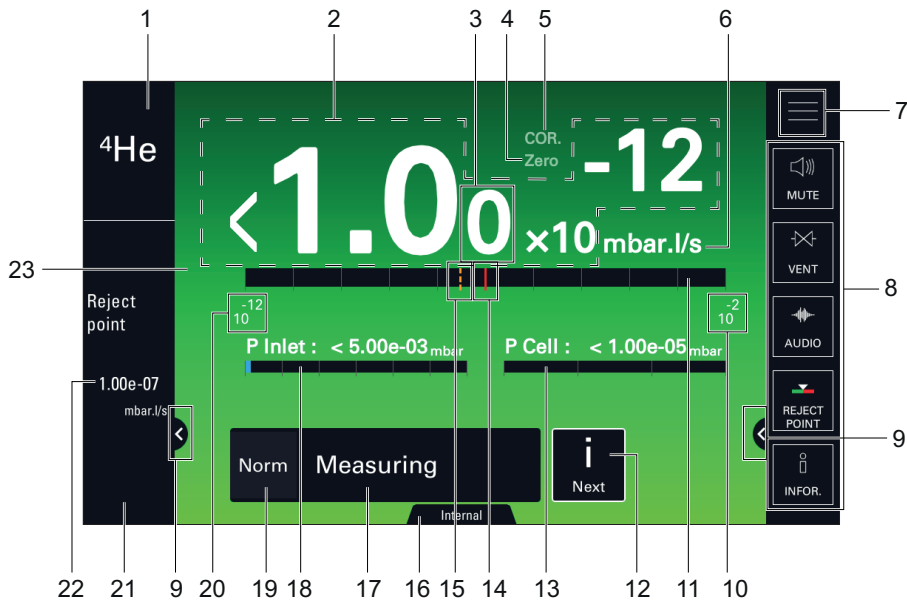

Item	Function	Name of the pictogram in the operating instructions
1	Tracer gas selected	-
2	Leak rate digital display	-
3 <sup>1)</sup>	Display 2 <sup>nd</sup> digit	-
4 <sup>1)</sup>	<b>Zero</b> indicator: zero function applied	<b>ZERO</b>
5 <sup>1)</sup>	<b>COR</b> indicator: correction factor applied	<b>COR</b>

- 1) Display according to detector settings
- 2) Display only
- 3) Display if test in progress

Item	Function	Name of the pictogram in the operating instructions
6	Leak rate unit	-
7	Access to the menu Settings	[SETTINGS]
8	Function key bar	-
9	Display/Hide an area	[EXPAND]
10	High decade (max) of the bargraph	-
11	Leak rate bargraph display (color according to test result)	-
12	[i Next] indicator: error/warning message to be viewed	[i Next]
13 <sup>1)</sup>	Analyzer cell pressure or external gauge pressure	-
14 <sup>3)</sup>	Set reject point (red plot)	-
15 <sup>1)</sup>	Warning point set (orange plot)	-
16	Calibration type selected	-
17	Current status of the detector	-
18 <sup>1)</sup>	Detector inlet pressure	-
19	Test mode selected	-
20	Low decade (min) of the bargraph	-
21 <sup>1)2)</sup>	Sniffer probe flow (if Sniffer method selected)	-
22 <sup>1)</sup>	Set reject point digital display	-
23	The color of the screen varies depending on the test result: <ul style="list-style-type: none"> <li>• green screen: measured leak rate below the reject point</li> <li>• red screen: measured leak rate above the reject point</li> </ul> Gray screen: detector in 'Stand-by' mode	-

1) Display according to detector settings

2) Display only

3) Display if test in progress

### 7.7.3 Graph screen

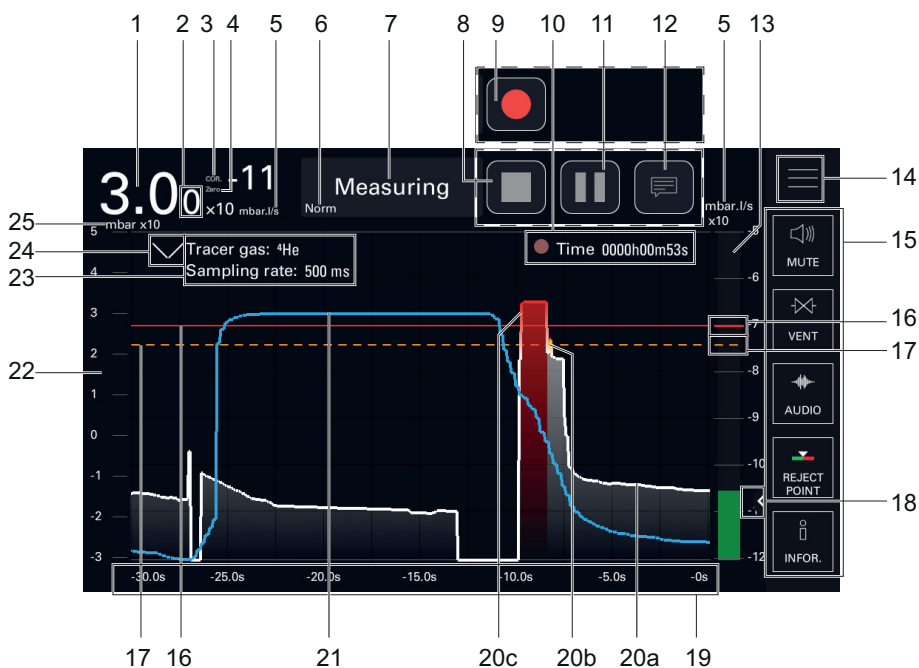

► Press on the screen to access the graph settings (see chapter "Graph screen: graph parameters").

Item	Function	Name of the pictogram in the operating instructions
1	Leak rate digital display	-
2 <sup>1)</sup>	Display 2 <sup>nd</sup> digit	-
3 <sup>1)</sup>	<b>COR</b> indicator: correction factor applied	<b>COR</b>
4 <sup>1)</sup>	<b>Zero</b> indicator: zero function applied	<b>ZERO</b>
5	Leak rate unit	-
6	Test mode selected	-
7	Current status of the detector	-
8 <sup>2)</sup>	Stop the recording	[STOP REC]
9 <sup>2)</sup>	Start recording	[START REC]
10 <sup>2)</sup>	Total recording time <ul style="list-style-type: none"> <li>• white dot: no recordings in progress</li> <li>• flashing red dot: recording in progress</li> <li>• fixed red dot: recording paused</li> </ul>	-
11 <sup>2)</sup>	Pause/Resume recording	[STBY REC]
12 <sup>2)</sup>	Comments access	[COMMENT]
13	Bar graph display of the leak rate <ul style="list-style-type: none"> <li>• Green bargraph: measured leak rate below the warning point</li> <li>• Orange bargraph: measured leak rate between the warning point and the reject point</li> <li>• Red bargraph: measured leak rate above the reject point</li> </ul>	-
14	Access to the menu Settings	[SETTINGS]
15	Function key bar	-
16	Set reject point (red plot)	-
17 <sup>1)</sup>	Warning point set (orange plot)	-
18	Display/Hide an area	[EXPAND]
19	Display time	-
20 <sup>3)</sup>	Leak rate plot <ul style="list-style-type: none"> <li>• 20a - white plot: measured leak rate below the warning point</li> <li>• 20b - orange bargraph: measured leak rate between the warning point and the reject point</li> <li>• 20c - red plot: measured leak rate above the reject point</li> </ul>	-
21	Detector inlet pressure plot (blue)	-
22	Detector inlet pressure range	-
23	Data on recording <ul style="list-style-type: none"> <li>• Tracer gas selected</li> <li>• Sampling rate set</li> </ul>	-
24	Show/hide data on recording (item 23)	-
25	Detector inlet pressure unit	-

1) Display according to detector settings

2) Display according to recording settings

3) Display if test in progress

### Navigation

The user can view some or all of a recording, without stopping the recording in progress.

- ▶ Drag the plot to the left/right to browse the recording in progress.
- ▶ Press on the graph screen then **[View record]** to view all of the recording in progress.

Graph

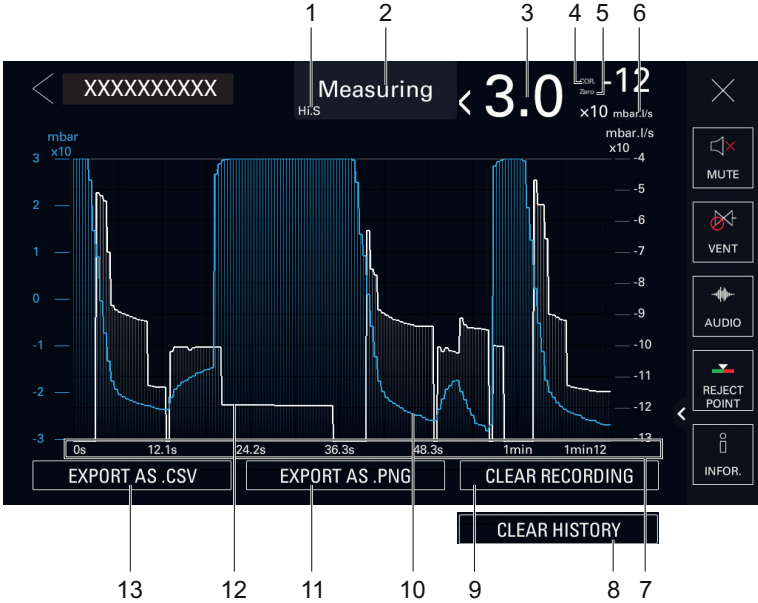

- 1 Test mode selected
- 2 Current status of the detector
- 3 Leak rate digital display
- 4 **COR** indicator: correction factor applied
- 5 **Zero** indicator: zero function applied
- 6 Leak rate unit
- 7 Total recording time
- 8 Button to delete the graph history
- 9 Button to clear the recording in progress
- 10 Inlet pressure plot (blue)
- 11 Button to save a .png screenshot
- 12 Leak rate plot (white)
- 13 Button to save a .csv file

### 7.7.4 Graph screen: graph parameters

Access: Press on the screen to access the graph parameters.			Choice - Setting limit <sup>1)</sup>	
Range	Display time	To be set Maximum time range displayed on the screen	12 s – 1 h	
	Auto scale	To be enabled The automatic scale is used to display the measured leak rate centered on 2 or 4 decades. The scale varies according to the leak rate measured. When auto scale is enabled, the scale configured for the leak rate is no longer taken into account. See example below	Enabled Disabled	
		if auto scale is enabled	To be selected Number of auto scale decades Example: leak rate = $5 \cdot 10^{-5}$ mbar · l/s ( $5 \cdot 10^{-6}$ Pa · m <sup>3</sup> /s) <ul style="list-style-type: none"> <li>Auto scale 2 decades: scale from <math>1 \cdot 10^{-4}</math> – <math>1 \cdot 10^{-6}</math> mbar · l/s (<math>1 \cdot 10^{-5}</math> – <math>1 \cdot 10^{-7}</math> Pa · m<sup>3</sup>/s)</li> <li>Auto scale 4 decades: scale from <math>1 \cdot 10^{-3}</math> – <math>1 \cdot 10^{-7}</math> mbar · l/s (<math>1 \cdot 10^{-4}</math> – <math>1 \cdot 10^{-8}</math> Pa · m<sup>3</sup>/s)</li> </ul>	2 decades 4 decades
	Decade if auto scale is disabled	High decade	To be set High decade (max) of the bargraph Note: Maximum of 10 decades between high and low decade	-11 – +6
		Low decade	To be set Low decade (min) of the bargraph Note: Maximum of 10 decades between high and low decade	-12 – +5
	Show inlet pressure	To be enabled Displaying/Hiding the inlet pressure		Enabled Disabled
	Pressure decade if 'Show inlet pressure' is enabled	High decade	To be set Configuration of the maximum decade for the inlet pressure	-2 – +3
Low decade		To be set Configuration of the minimum decade for the inlet pressure	-3 – +2	
Enable record	To be enabled Show/hide <b>[COMMENT]</b> , <b>[START REC]</b> , <b>[STBY REC]</b> and <b>[STOP REC]</b> on the graph screen (see chapter "Graph screen").		Enabled Disabled	
Sampling rate if 'Enable record' is enabled	To be set Time between 2 recorded measurements		100 ms – 30 s	
Clear recording if 'Enable record' is enabled	Function to be started This function deletes all recordings in progress.		-	
View record if 'Enable record' is enabled	Function to be started This function is used to display all recordings in progress.		-	

1) Initial setting: see chapter "Tree diagram to the Settings menu"



### 7.7.5 Graph screen: recording

Recording is used to store the measurements taken during the test in the control panel memory. **It will not save these measurements.**

**For each measurement, the leak rate and inlet pressure are recorded.**

During recording, all of the leak detector functions are available.

After the detector is turned off (by a power failure or user manual shutdown), the current recording is cleared.

A record may include several measurements. The successive measurements are recorded one after the other in the recording: a visual cue ( $\Delta$ ) indicates the measure change.

To start a new recording, you must first save the current one.

When the memory is full and a recording is in progress, recording is automatically stopped.

1. Update the recording settings if necessary (see chapter "Graph screen: graph parameters").
2. Press **[COMMENT]** to add a comment (see chapter "Graph screen").
  - Optional: this comment can be added at any time during the recording or during a pause
  - Comments can be viewed later in the backup .CSV file.
3. Press **[START REC]** to start recording.
  - **[START REC]** is replaced by: **[STOP REC]**, **[STBY REC]** and **[COMMENT]**.
  - Total recording duration: a flashing round dot is displayed, indicating that a recording is in progress.
  - None of the measurements displayed on the plot before the recording starts will be recorded.
4. If necessary, press **[STBY REC]** to pause.
  - The pictogram glows red without flashing.
  - Total recording duration: the red dot is steady, indicating that the recording is paused.
  - None of the measurements displayed on the plot during the pause will be recorded.
5. Press **[STBY REC]** again to re-start recording.
6. Repeat the previous steps as many times as necessary.
7. Press **[STOP REC]** to stop recording.
  - Return to the recording in progress to continue (the measures already saved will be retained): press **[<]** then **[START REC]**.
  - To stop and save the recording in progress: press **[STOP REC]** (see chapter "Graph screen: saving a recording").

### 7.7.6 Graph screen: graph history

The Graph history automatically records a history of the leak rate and inlet pressure values once the leak detector is on. It is not the user who triggers recording of the history. **They do not save these values.**

The history recording continues even when the user has started a recording (see chapter "Graph screen: recording").

The history is recorded in the leak detector's buffer memory.

The maximum duration of the history recording depends on the current setting:

- 12 s display time: 60 min history recording
- 1 h display time: 298 h history recording ( $\approx$  12.4 days)

► Double press on the graph screen to view the Graph history.

The user can save the recording of the history: see chapter "Graph screen: save".

The user can zoom in on the recording of the history: see chapter "Graph screen: viewing".

The user can view the details of each point in the history recording: see chapter "Graph screen: viewing".

### 7.7.7 Graph screen: save and delete

The user can save the following recordings:

- recording in progress (see chapter "Graph screen: recording").
- graph history recording (see chapter "Graph screen: graph history")

It is saved in the form of a file (.csv) or a screenshot (.png)

Saving is not automatic.

The saved recording can be stored in a USB stick or in the internal memory of the detector.

View a saved file: see chapter "Graph screen: viewing".

#### Saving a file (.csv)

The saved file (.csv) contains all the measurements taken (leak rate and inlet pressure) during the recording. It allows further processing.

The default separator is "tab".

The default name of the file (.csv) is RecordYYYYMMDD\_HHMMSS (example: Record20210727\_143635).

1. Start a recording (see chapter "Graph screen: recording") or display the graph history (see chapter "Graph screen: graph history").
2. Press **[STOP REC]** to stop recording (see chapter "Graph screen").
3. Press **[Export as .CSV FILE]**.
  - Automatic opening of the File Manager menu window
4. Select the storage location (**[Internal Memory]** or **[USB Stick]**) for the file to be saved.
5. Press the lower left frame and enter the name of the file to be saved.
6. Press **[✓]** to confirm the entry.
7. Press **[SAVE]** to complete the save.
  - The message "Record file saved successfully" is displayed to confirm the save.

#### Save a screenshot (.png)

The screenshot (.png) displays all the measurements taken (leak rate or inlet pressure) during the recording.

To save the plot of the leak rate measurements and the plot of the inlet pressure measurements, the procedure must be carried out twice while viewing each of the plots (see chapter "Graph screen").

The default name of the screenshot (.png) is ScreenYYYYMMDD\_HHMMSS (Example: Screen20210203\_143302).

1. Start a recording (see chapter "Graph screen: recording") or display the graph history (see chapter "Graph screen: graph history").
2. Press **[STOP REC]** to stop recording (see chapter "Graph screen").
3. View the plot to save (see chapter "Graph screen")
4. Press **[Export as .PNG]**.
  - Automatic opening of the File Manager menu window
5. Select the storage location (**[Internal Memory]** or **[USB Stick]**) for the file to be saved.
6. Press the lower left frame and enter the name of the file to be saved.
7. Press **[✓]** to confirm the entry.
8. Press **[SAVE]** to complete the save.
  - The message "Record file saved successfully" is displayed to confirm the save.
9. Optional: to save a screenshot of the 2<sup>nd</sup> plot.
  - View the 2<sup>nd</sup> plot to save (see chapter "Graph screen")
10. Do steps 4 to 8 again.

#### Delete a recording

The user can delete the following recordings:

- recording in progress (see chapter "Graph screen: recording").
- graph history recording (see chapter "Graph screen: graph history")
  - Clearing the recording of the graph history deletes the entire leak detector buffer memory.

1. Display the recording to be deleted.
2. Press **[CLEAR GRAPH]** to clear the recording (see chapter "Graph screen").
3. Press **[CLEAR HISTORY]** to delete the graph history (see chapter "Graph screen").
4. Press **[OK]** to confirm.

### 7.7.8 Graph screen: display

The user can display the following recordings:

- recording in progress (see chapter "Graph screen: recording").
- recording saved (see chapter "File manager menu").
  - A recording can be viewed even if it is in progress.
- graph history (see chapter "Graph screen: graph history")
  - A recording can be viewed even if it is in progress.

The user can view the details of a measurement for each point saved (see chapter "Details of a measurement").

The user can zoom in on the current display (see chapter "Zoom function").

**Recording in progress**

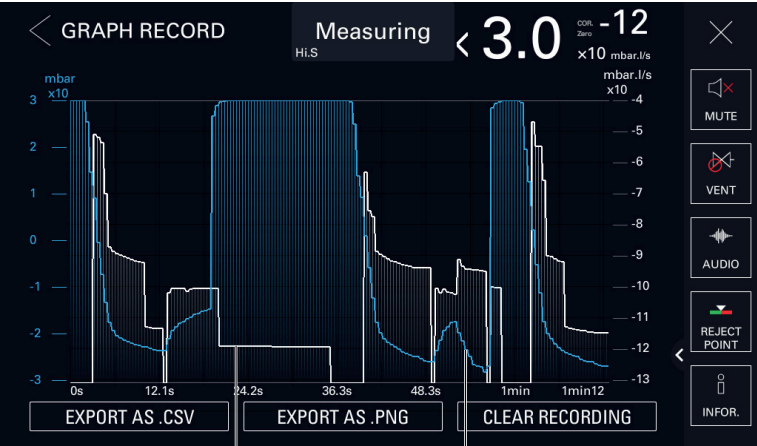

- 1 Leak rate plot (white)
- 2 Inlet pressure plot (blue)

**Recording saved**

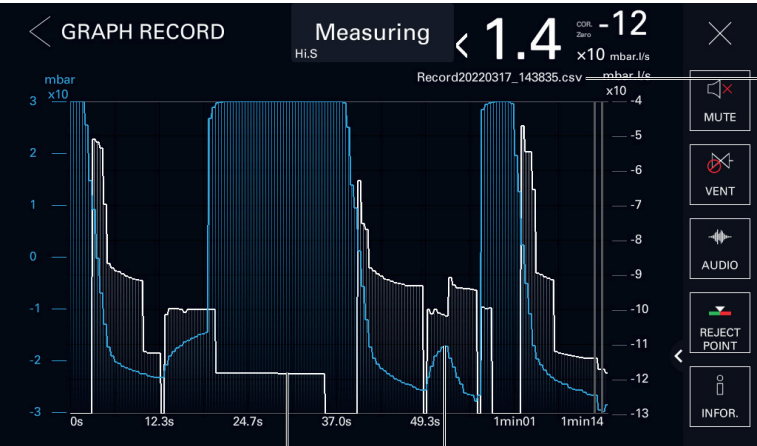

- 1 Viewed file name
- 2 Inlet pressure plot (blue)
- 3 Leak rate plot (white)

**Graph history**

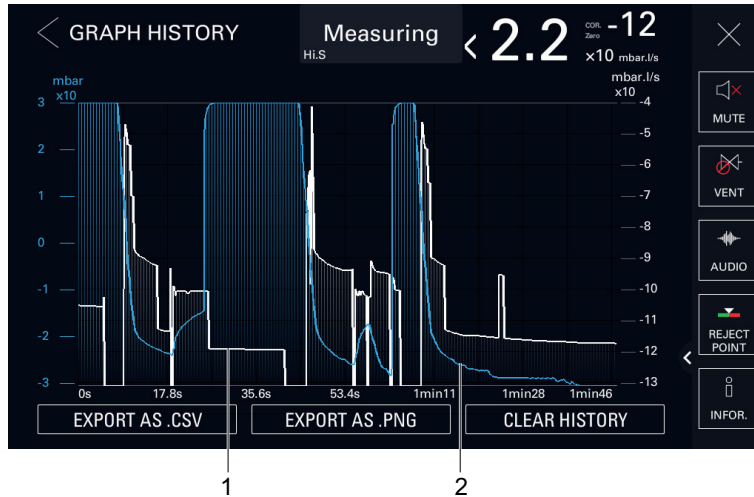

- 1 Leak rate plot (white)
- 2 Inlet pressure plot (blue)

**7.7.9 Details of a measurement**

The user can view the details of a measurement (leak rate and inlet pressure) for each point of the recording in progress, the graph history, or saved recording (.csv file).

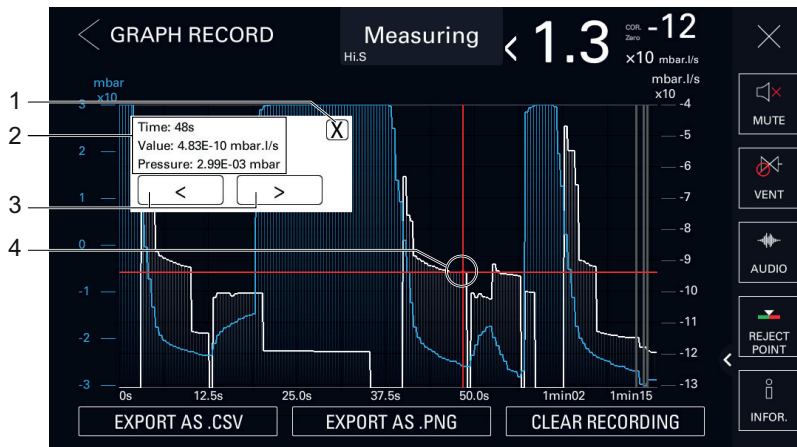

- 1 Window closes
- 2 Details of the selected measurement:
  - Time: the time of measurement with regard to the end of the recording
  - Value: exact value of the leak rate measured
  - Pressure: exact value of the inlet pressure measured

1. Press the measurement point on the plot to be viewed until a red cross appears.
  - A window with details appears.
  - Press [X] to close the window.
2. To adjust the selection, move forward/backward from point to point by pressing the navigation tools.

**7.7.10 Zoom function**

At any time, it is possible to zoom in on the display.

A pictogram appears once the zoom function is enabled. It disappears when the zoom function is no longer applied.

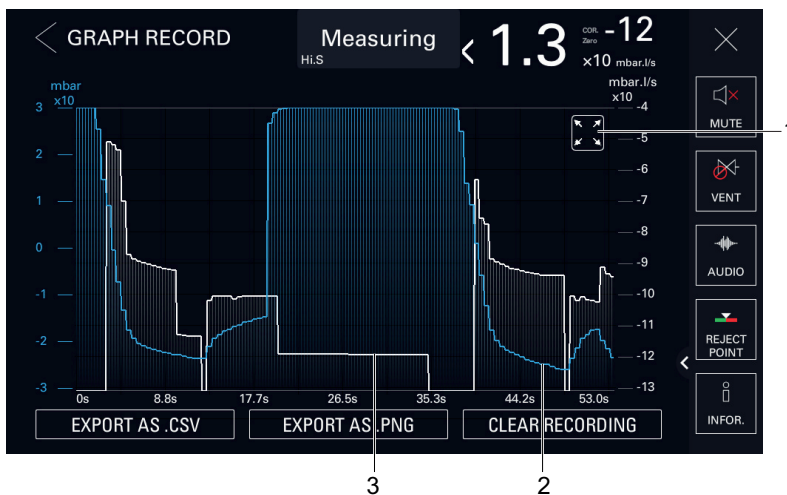

















- 1 Pictogram indicating that the zoom function is applied
- 2 Inlet pressure plot (blue)
- 3 Leak rate plot (white)

- ▶ To zoom in, place two fingers on the touch screen area and move them away from each other.
- ▶ To zoom out, place two fingers slightly apart from each other on the touch screen and bring them towards each other.

### 7.7.11 Function key bar

The function key bar is used to view settings, access a menu (shortcut) or start a direct action.

	Pictogram	Name of the pictogram in the operating instructions
Function keys permanently displayed		[MUTE]
		[VENT]

	Pictogram	Name of the pictogram in the operating instructions
Function keys available depending on the setting		[AUDIO]
		[CAL. TYPE]
		[COR.]
		[INFOR.]
		[MEMO]
		[METHOD]
		[MODE]
		[PAGING]
		[REGEN]
		[REJECT POINT]
		[SCREEN SHOT]
		[SWITCH SETPOINT]
		[TIMER]
		[TRACER GAS]

**Description of the function key bar**

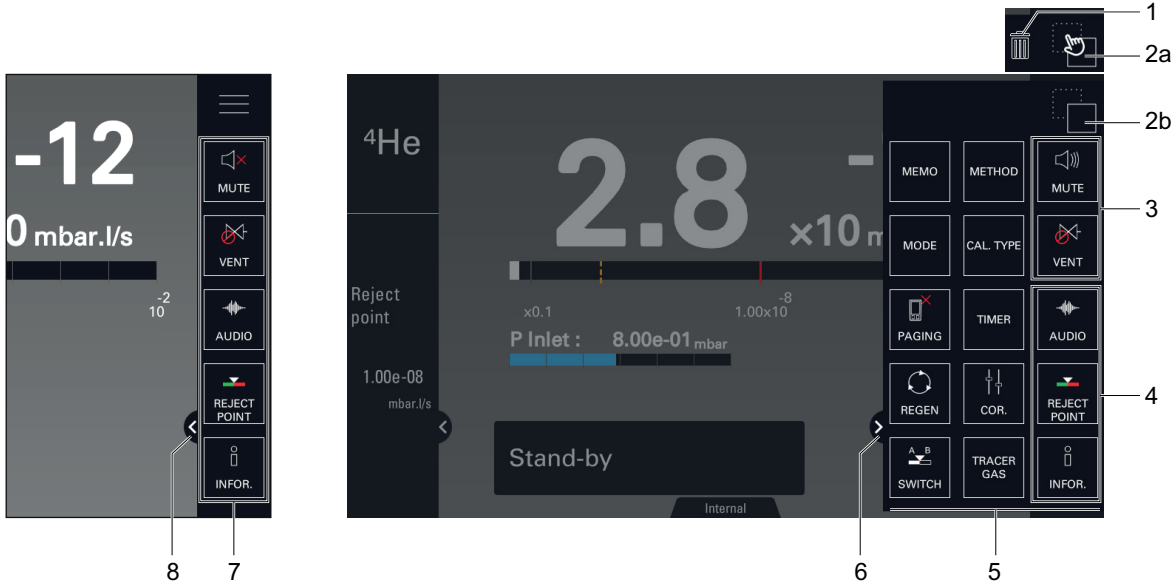

- |                              |  |
|------------------------------|--|
| 1 Bin                        | 5 Additional function keys available (see chapter "Function keys") |
| 2a Setting access button     | 6 Close the function key bar                                       |
| 2b Setting validation button | 7 5 function keys permanently displayed                            |
| 3 2 permanent function keys  | 8 Open the function key bar  |
| 4 3 adjustable function keys |  |

**Function key permanently displayed in the bar**

- Only the 5 function keys on the right side of the bar are displayed permanently.
- The other function keys available can be accessed by opening the bar.

Example: Switching the [REJECT POINT] and [MEMO] function keys

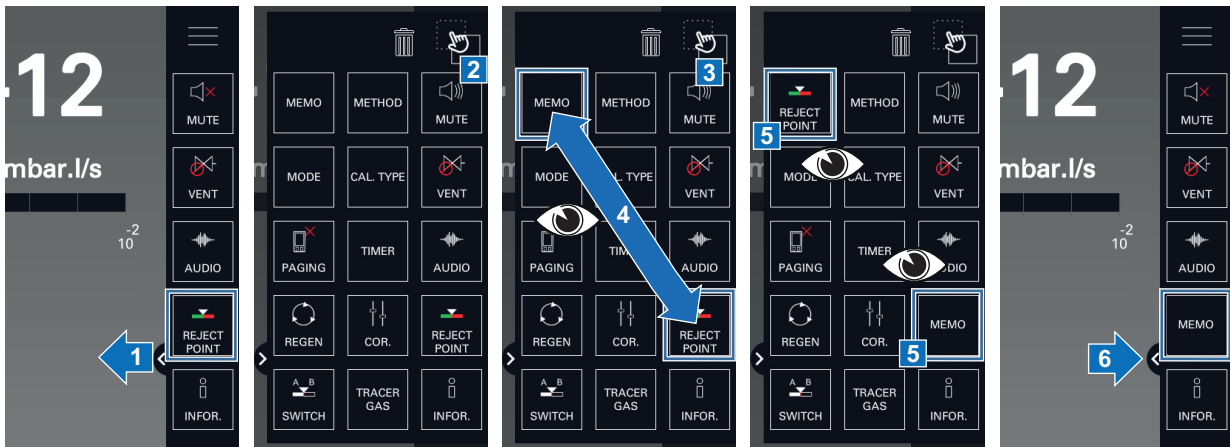

 The user switches a function key by dragging one function key to replace another.

**Removing a function key from the bar**

- It is also possible to delete a function key from the bar by disabling it (see chapter "Function keys").
- To display a deleted/disabled function key in the bar, it must be enabled again (see chapter "Function keys").

Example: Remove the [MEMO] function key

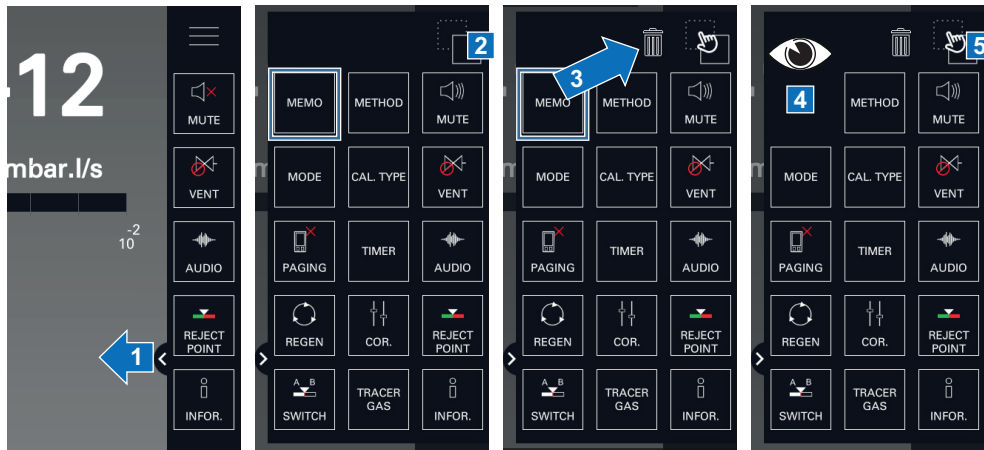



## 8 Settings menu

The Settings menu allows the user to set the product according to its specific use.

The functions of the Settings menu are divided into 6 menus.

- ▶ From the control panel, press **[SETTINGS]** (see chapter “Home” or “Graph screen”).

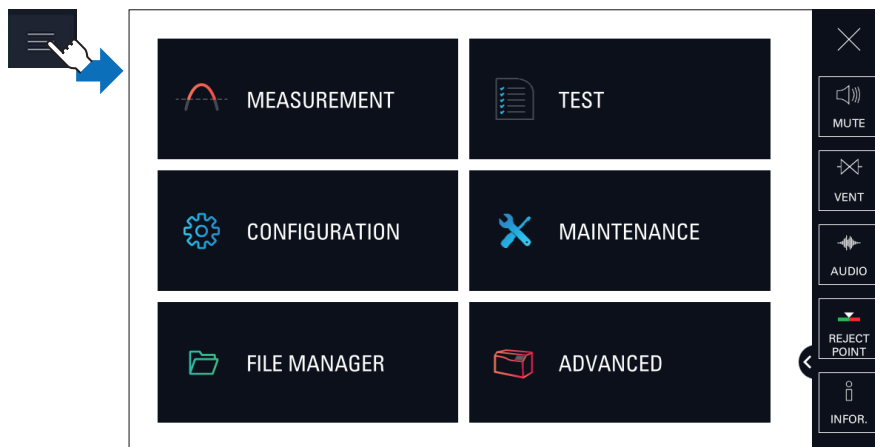

---

### Functions by menu

---

#### MEASUREMENT menu

- Tracer gas
- Set points
- Correction factor
- Calibrated leak settings
- Target value

---

#### TEST menu

- Method
- Mode
- Probe type
- Cycle end
- Inlet vent
- Memo Function
- Zero activation
- Regeneration
- Massive mode
- Calibration check
- Calibration mode
- Dynamic calibration
- Purge valve
- Start-up timer
- Crossover pressures

---

#### CONFIGURATION menu

- Unit
- Date
- Time
- Language
- Sound volume
- Function keys
- Screen settings
- Access/Password

---

#### MAINTENANCE menu

- History
  - Information
  - Last maintenance operations
  - Timers before next maintenance
  - Maintenance turbo pump and cell
  - Burn-in
  - Internal Pirani Calibration
  - External gauge
  - Save LD Parameters
-

**Functions by menu**

**FILE MANAGER** menu

**ADVANCED** menu

- Input/Output
- Service

**Temporary access to a locked menu**

Temporary access: after returning to the main screen, the menu is once again locked.

► See chapter “Access - Password”.

**Permanent display on the setting menus**

The leak rate can be viewed at any time by the user.

The leak rate is permanently displayed on the settings menus (except on the 'File manager' menu).

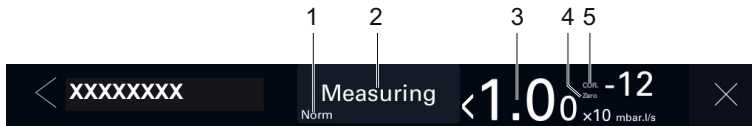

- 1 Current status of the detector
- 2 Test mode selected
- 3 Digital display of leak rate and its unit
- 4 **Zero** indicator: zero function applied
- 5 **COR** indicator: correction factor applied

## 8.1 Measurement menu

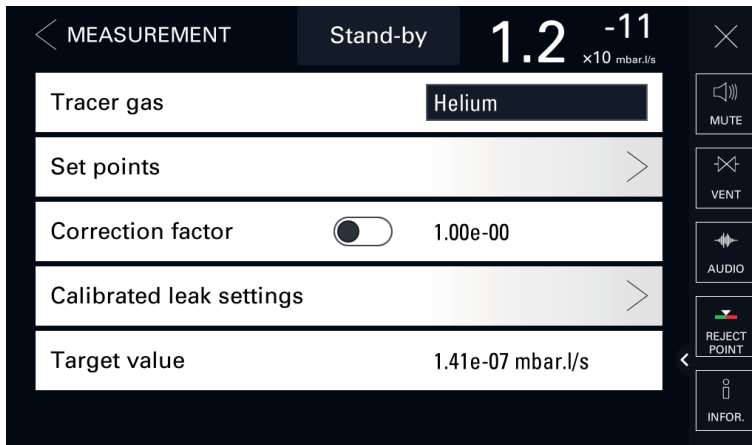

### 8.1.1 Tracer gas

This menu is used to select the tracer gas.

Access: Menu [Measurement] [Tracer Gas]		Choice - Setting limit <sup>1)</sup>
Tracer gas	To be selected The tracer gas is the gas searched for during a test.	Helium 4 Mass 3 Hydrogen

1) Initial setting: see chapter “Tree diagram to the Settings menu”



For quick access from the main screen, use the **[TRACER GAS]** function key.

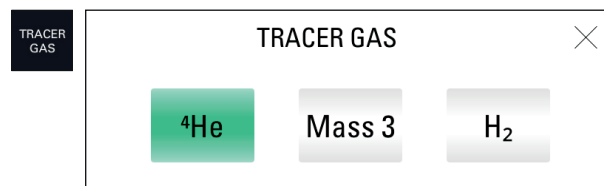

## 8.1.2 Set points

This menu is used to define the different set points (pollution, test, pressure).

Access: Menu [Measurement] [Set points]		Choice - Setting limit <sup>1)</sup>
Pollution	To be enabled This is a safety device for the detector. It prevents too much leaked tracer gas from penetrating the detector. We recommend setting the pollution set point to a maximum of 4 decades above the reject set point. If the leak rate rapidly increases above the pollution set point, the cycle stops automatically and the leak detector returns to 'Stand-by' mode. The function is only available with the 'hard vacuum' test method. <b>Useful function if the part or installation to be tested is likely to have gross leaks.</b>	Enabled Disabled
	To be set	$1 \cdot 10^{-19}$ – $1 \cdot 10^{+19}$
Hard Vacuum Set Points	Reject point To be set for each tracer gas The reject point is the acceptance set point for parts. <ul style="list-style-type: none"> <li>Measured leak rate &lt; reject point: part accepted</li> <li>Measured leak rate &gt; reject point: part rejected</li> </ul> The set point is not displayed on the main screen or graph screen when the detector is in 'Stand-by' mode.	$1 \cdot 10^{-13}$ – $1 \cdot 10^{-06}$
	Warning point To be enabled The warning point is an intermediate set point defined according to the reject point. It indicates that the user is approaching the reject point, but the part tested is good. The set point is not displayed on the main screen or graph screen when the detector is in 'Stand-by' mode. Display of the test result: see details below.	Enabled Disabled
	To be set Example: reject point = $5 \cdot 10^{-5}$ -> if 20%, warning point = $1 \cdot 10^{-5}$	0–100%
Sniffer set points	Reject point To be set for each tracer gas The reject point is the acceptance set point for parts. <ul style="list-style-type: none"> <li>Measured leak rate &lt; reject point: part accepted</li> <li>Measured leak rate &gt; reject point: part rejected</li> </ul> The set point is not displayed on the main screen or graph screen when the detector is in 'Stand-by' mode.	$1 \cdot 10^{-12}$ – $1 \cdot 10^{+06}$
	Probe Clogged To be set The probe clogged set point is used to verify that the sniffer probe (accessory) is operational. When the probe flow is below the 'Probe clogged' set point, a code is displayed to inform the operator.	$1 \cdot 10^{-19}$ – $1 \cdot 10^{+19}$
	Warning point To be enabled The warning point is an intermediate set point defined according to the reject point. It indicates that the user is approaching the reject point, but the part tested is good. Display of the test result: see details below.	Enabled Disabled
	To be set Example: reject point = $5 \cdot 10^{-5}$ -> if 20%, warning point = $1 \cdot 10^{-5}$	0–100%

1) Initial setting: see chapter "Tree diagram to the Settings menu"

Access: Menu [Measurement] [Set points]		Choice - Setting limit <sup>1)</sup>
Other set points	To be set 4 additional hard vacuum reject points (reject point #2/3/4/5), managed by the communication interface (see the operating instructions for the interface (see chapter “Applicable Documents”)), are available. The function is only available with the ‘hard vacuum’ test method. Detector equipped with 37-pin I/O communication interface (option/accessory). Example: reject point = $5 \cdot 10^{-5}$ -> if 20%, warning point = $1 \cdot 10^{-5}$ $5 \cdot 10^{-5} - 3 \cdot 10^{+2}$	$1 \cdot 10^{-12}$ – $1 \cdot 10^{+06}$
Other pressure set points	To be set 2 additional pressure set points (pressure set point #1/2), managed by the communication interface (see the operating instructions for the interface (see chapter “Applicable Documents”)), are available. The function is only available with the ‘hard vacuum’ test method. Detector equipped with 37-pin I/O communication interface (option/accessory). Installation equipped with an external gauge (customer’s responsibility) Pressure reject point 1 must always be greater than pressure reject point 2	$1 \cdot 10^{-19}$ – $1 \cdot 10^{+19}$

1) Initial setting: see chapter “Tree diagram to the Settings menu”



For quick access from the main screen, use the [REJECT POINT] function key.

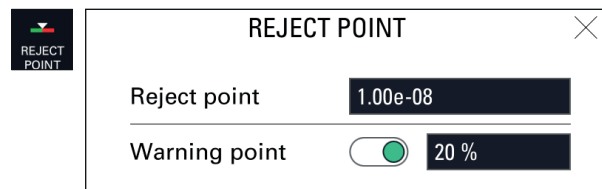

### Display of the test results

Test result	Display Control panel
Leak rate below the warning point or the reject point if the warning point is disabled	Screen: green Bargraph: white Graph: white line
Leak rate between warning point and reject point	Screen: green Bargraph: orange Graph: orange line
Leak rate greater than the reject point	Screen: red Bargraph: white Graph: red line

### Switch set point function

The Switch set point function is used to store 2 reject points and then assign one to the hard vacuum test or sniffer reject point (depending on the test method set).

- Allocate a function key to [SWITCH SETPOINT] (see “Function keys”).

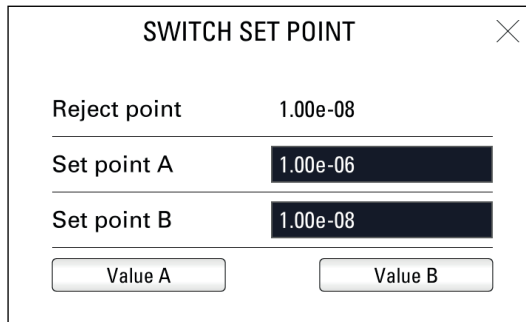

Access: [SWITCH SETPOINT]		Choice - Setting limit <sup>1)</sup>
Reject point	Read only Set reject point <ul style="list-style-type: none"> <li>• hard vacuum test set point or sniffer set point depending on the test method set</li> <li>• Set point for the tracer gas selected</li> </ul>	-
Set point A	To be set Reject point A is an acceptance set point for parts.	$1 \cdot 10^{-13} - 1 \cdot 10^{+06}$
Set point B	To be set Reject point B is an acceptance set point for parts.	$1 \cdot 10^{-13} - 1 \cdot 10^{+06}$
Value A	Function launching Allocation of the reject point value A to the reject point	-
Value B	Function launching Allocation of the reject point value B to the reject point	-

1) Initial setting: see chapter "Tree diagram to the Settings menu"

### 8.1.3 Correction factor

The correction factor is used to correct the leak rate measured by the leak detector when the tracer gas concentration is less than 100%.

A light indicating that the function is enabled is displayed on the main screen.



Use of the correction factor must not replace calibration.

Access: Menu [Measurement] [Correction factor]		Choice - Setting limit <sup>1)</sup>
Correction factor	To be enabled	Enabled Disabled
	To be set	$1 \cdot 10^{-18} - 1 \cdot 10^{+18}$

1) Initial setting: see chapter "Tree diagram to the Settings menu"



For quick access from the main screen, use the [COR.] function key.

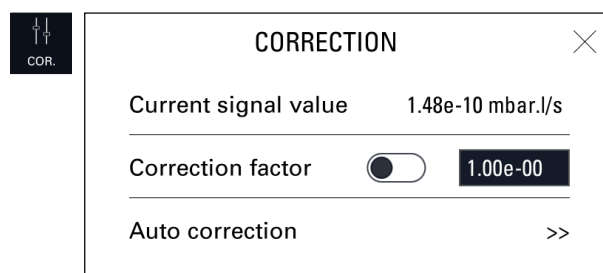

#### Example

The table below shows the leak rate displayed according to the correction factor applied.

Example: leak rate displayed with a calibrated leak of  $1 \cdot 10^{-5}$  mbar · l/s ( $1 \cdot 10^{-6}$  Pa · m<sup>3</sup>/s) (with 100% <sup>4</sup>He)

% He in the gas used	100%	50%	5%	1%
Leak rate displayed on the leak detector without correction factor	$1 \cdot 10^{-5} \text{ mbar} \cdot \text{l/s}$ ( $1 \cdot 10^{-6} \text{ Pa} \cdot \text{m}^3/\text{s}$ )	$5 \cdot 10^{-6} \text{ mbar} \cdot \text{l/s}$ ( $5 \cdot 10^{-7} \text{ Pa} \cdot \text{m}^3/\text{s}$ )	$5 \cdot 10^{-7} \text{ mbar} \cdot \text{l/s}$ ( $5 \cdot 10^{-8} \text{ Pa} \cdot \text{m}^3/\text{s}$ )	$1 \cdot 10^{-7} \text{ mbar} \cdot \text{l/s}$ ( $1 \cdot 10^{-8} \text{ Pa} \cdot \text{m}^3/\text{s}$ )
Correction factor value	1	2	20	100
Leak rate displayed on the leak detector with correction	$1 \cdot 10^{-5} \text{ mbar} \cdot \text{l/s}$ ( $1 \cdot 10^{-6} \text{ Pa} \cdot \text{m}^3/\text{s}$ )			

**Display**

The **COR** indicator light is displayed on the control panel when the correction factor value is not 1.

The leak rate displayed takes into account the correction factor applied.

**Correction factor calculation**

When the leak detector is connected to an installation equipped with its own pumping system, only part of the leak will be measured by the leak detector. Calibration gives a direct reading of the leak rate by taking into account the loss of tracer gas of the leak pumped by the pumping unit.

Calibration is performed via the Correction function.

Correction must be performed when the leak detector is already calibrated with its internal calibrated leak.

When an external calibrated leak is used, it is recommended to take into account the calibration date and temperature effect for calculating the target value from the calibrated leak value featured on its identification label.

Corrected leak rate = target value = measured leak value x correction factor

1. Allocate a function key to **[COR.]** (see "Function keys").
2. Select the 'hard Vacuum' test method (see chapter "Test method").
3. Press the **START/STOP** button to start a test.
4. Press the **[COR.]** function key.
5. Enable the correction factor.
6. If the value of the correction factor to be applied is known:
  - a Press **[Value]**.
  - b Set the correction factor to be applied. The correction factor is the coefficient to be applied to the measured leak rate.
  - c Press **[✓]**.
  - c Press **[X]**.
7. If the value of the correction factor is unknown:
  - a Press **[>>]** to access the 'Auto Correction' function.

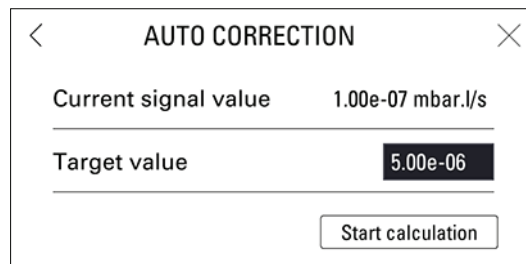

- b Press **[Target Value]**.
  - c Set the target leak rate of the target value.
  - d Press **[Start Calculation]**.
  - e Press **[X]** to exit the function.
8. if no factor is enabled, it is 1 by default

The value of the correction factor is calculated automatically and updated.

The **COR** indicator light is displayed on the control panel when the value of the correction factor is not 1.

The 'Auto correction' function is automatically enabled.

The digital display takes into account the applied correction factor.

The bargraph display does not take into account the applied correction factor.

### 8.1.4 Calibrated leak settings

This menu is used to enter and view the settings of the calibrated leaks (see chapter “Calibration”).

- ▶ Update these settings when changing or recalibrating a calibrated leak.

Access: Menu [Measurement] [Calibrated leak settings]		Choice - Setting limit <sup>1)</sup>
Tracer gas	To be selected The tracer gas is the gas searched for during a test. This is the gas contained in the calibrated leak used for calibration.	Helium 4 Mass 3 Hydrogen
Type	To be selected Type of calibrated leak used for calibration <ul style="list-style-type: none"> <li>• Internal: calibration based on the detector's internal calibrated leak 'Hard vacuum' test method only</li> <li>• External: calibration based on external calibrated leak (<sup>4</sup>He, Mass 3 or H<sub>2</sub> leak).</li> <li>• Concentration: calibration from a gas mixture for which the tracer gas concentration is known. Sniffer test method only</li> </ul>	Internal External Concentration
Unit	To be selected Unit of calibrated leak used for calibration <sup>2)</sup>	mbar · l/s Pa · m <sup>3</sup> /s Torr · l/s mTorr · l/s atm · cc/s sccm sccs ppm <sup>3)</sup>
Leak value	To be set Value of calibrated leak used for calibration <sup>2)</sup>	$1 \cdot 10^{-18} - 1 \cdot 10^{+18}$
Loss per year (%)	To be set Set the loss per year for the calibrated leak used for calibration <sup>2)</sup>	0 – 99
Reference temperature (°C)	To be set Reference temperature for the calibrated leak used for calibration <sup>2)</sup>	0 – 99
Temperature coefficient (%/°C)	To be set Temperature coefficient for the calibrated leak temperature used for calibration <sup>2)</sup>	0.0 – 9.9
Date	To be set Month and year of calibration for the calibrated leak used for calibration <sup>2)</sup> Format: MM/YYYY	-
Type	To be selected Source of displayed temperature <ul style="list-style-type: none"> <li>• Internal: measured temperature by the internal calibrated leak temperature sensor</li> <li>• External: set temperature by the operator</li> </ul>	Internal External
Internal Temperature (°C) (if internal 'Type')	Read only Temperature of the detector's internal calibrated leak	-
External Temperature (°C) (if external 'Type')	To be set Configuration of external temperature	0 – 99

1) Initial setting: see chapter “Tree diagram to the Settings menu”

2) Use the information indicated on the calibrated leak used for calibration or on its calibration certificate.

3) If sniffer test method selected

## Settings menu

When the parameters are saved, all the data from all the set calibrated leaks (1 internal leak (<sup>4</sup>He) and 3 external leaks (<sup>4</sup>He, Mass 3 and H<sub>2</sub>)) is stored.

### 8.1.5 Target value

The target value is the value of the calibrated leak measured and corrected for temperature, taking into account the loss/year.

The temperature and the loss/year must be taken into account on calculating the target value.

This information is provided on the calibrated leak identification label.

#### Access: Menu [Measure] [Target Value]

Target value	Read only
--------------	-----------

## 8.2 Test menu

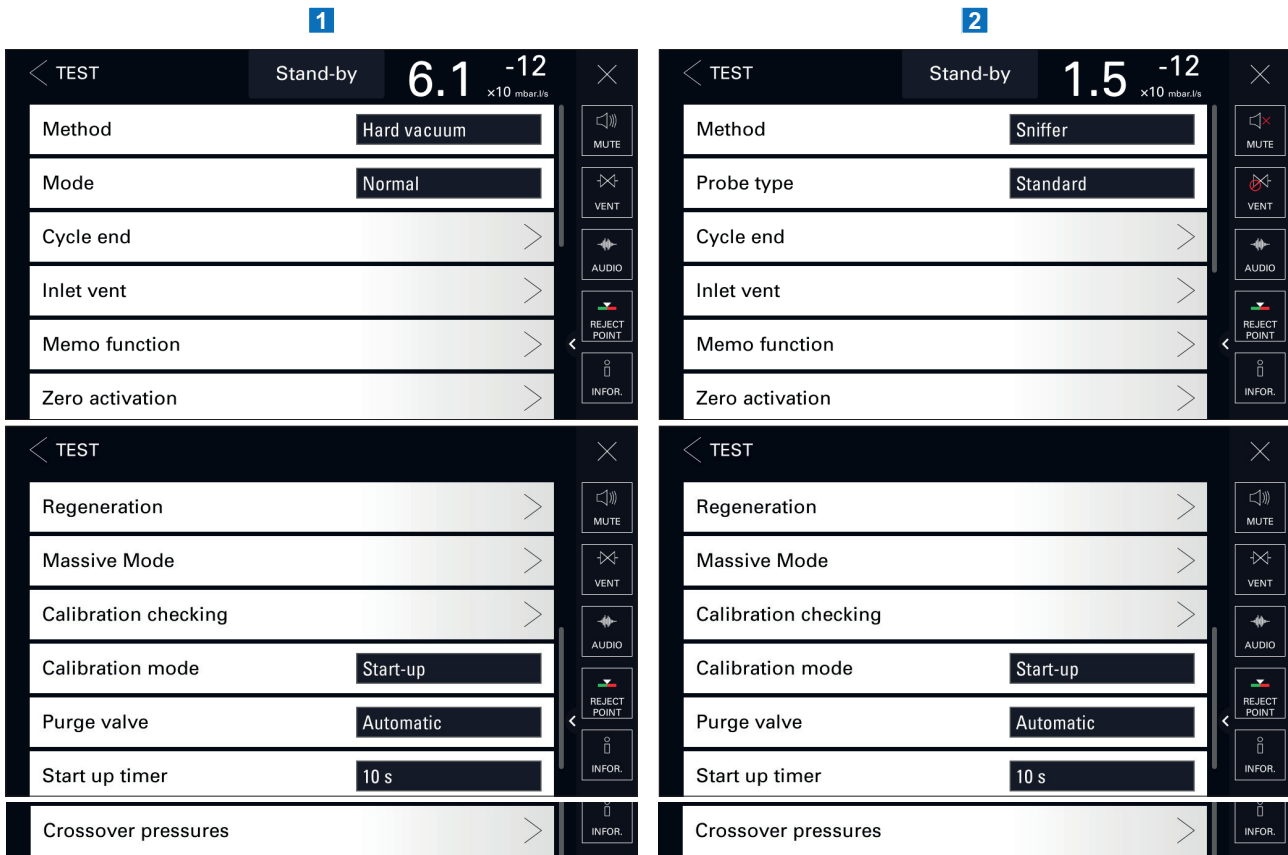

Example: Wet and Dry models

1 Test method: hard vacuum

2 Test method: Sniffer

### 8.2.1 Test method

This menu is used to select a test method.

#### Access: Menu [Test] [Method]

#### Choice - Setting limit <sup>1)</sup>

Method	To be selected The test method is chosen depending on the part to be tested. For more information about leak detection test methods, see <b>Leak detector compendium</b> on the <a href="http://www.pfeiffer-vacuum.com">www.pfeiffer-vacuum.com</a> website.	Hard Vacuum Sniffer
--------	--	------------------------

1) Initial setting: see chapter "Tree diagram to the Settings menu"





For quick access from the main screen, configure a function key to **[METHOD]** (see chapter “Function keys”).

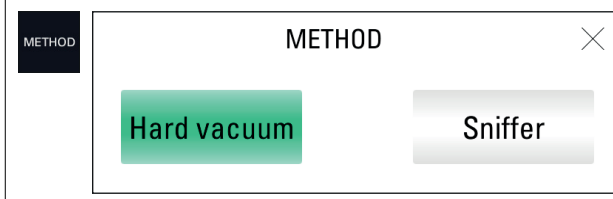

By default, the leak detector is set to work in a hard vacuum test, in the most sensitive test mode: this setting meets the majority of users’ needs.

### 8.2.2 Test mode

This menu lets you to select a test mode with the hard vacuum test method.

The leak detector will automatically switch to the test mode selected when the internal pressure reaches the crossover set point (see chapter “Crossover pressures”).

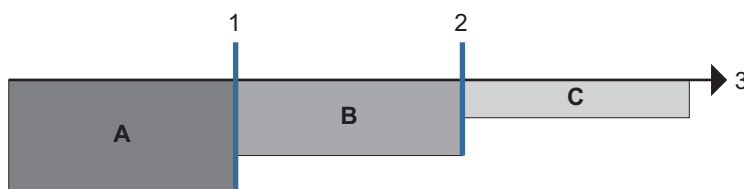

- A Roughing
- B Gross Leak mode
- C Normal mode

- 1 Set point for switching to Gross Leak mode
- 2 Set point for switching to Normal mode
- 3 Pressure

Access: Menu [Test] [Mode]		Choice - Setting limit <sup>1)</sup>
Mode	To be selected	Gross Leak Normal

1) Initial setting: see chapter “Tree diagram to the Settings menu”



For quick access from the main screen, configure a function key to **[MODE]** (see chapter “Function keys”).

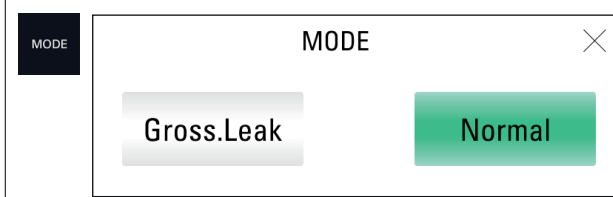

By default, the leak detector is set to work with 'hard vacuum' test method and 'normal' test mode: this setting meets the majority of users’ needs.

### 8.2.3 Type of probe

This menu is used to select the sniffer probe mode used in sniffer (see chapter “Accessories”).

Access: Menu [Test] [Probe type]		Choice - Setting limit <sup>1)</sup>
Probe type	To be selected Standard sniffer probe: model with rigid nozzle only	Standard Smart

1) Initial setting: see chapter “Tree diagram to the Settings menu”



Set the probe clogged set point to verify that the sniffer probe is operational (see chapter "Set points").

### 8.2.4 Cycle end

This function allows automatic check of the roughing time and test timer in a hard vacuum test.

Access: Menu [Test] [Cycle end]		Choice - Setting limit 1)
Cycle end	To be selected <ul style="list-style-type: none"> <li>Operator: manual cycle end by the user</li> <li>Automatic: automatic cycle end based on configuration below</li> </ul>	Operator Automatic
Roughing timer (If automatic 'Roughing timer')	To be enabled Roughing duration check	Enabled Disabled
	To be set (optional) Maximum permitted roughing duration If the control is enabled and time expires (detector still in roughing) = part rejected	0 – 1 h
Test timer (If automatic 'Test timer')	To be set (required) Duration of measurement When time expires, the measured leak rate is displayed.	0 – 1 h

1) Initial setting: see chapter "Tree diagram to the Settings menu"



Function to be used to automate a small production.

### 8.2.5 Inlet vent

This function allows an inlet vent after a hard vacuum test stop.

This function is used to return to atmospheric pressure the detector's inlet, and therefore the connected part or installation.

This function is secure: confirmation is requested each time the operator requests an inlet vent.

**CONFIRMATION START VENT**

Are you sure to ask for starting vent action ?

#### NOTICE

**Risk of pollution of the test chamber or of the process**

Never program an 'automatic' inlet vent when the detector is connected to a hard vacuum test or process chamber.

- ▶ Select 'Operator' and delete the function key allocated to the automatic inlet vent. The inlet vent must be carried out using the menu, which can be password locked.

Access: Menu [Test] [Inlet vent]		Choice - Setting limit <sup>1)</sup>
Inlet vent	To be selected <ul style="list-style-type: none"> <li>Operator: the inlet vent is carried out by the user by pressing on the <b>[VENT]</b> function key or on the corresponding pictograph on the main screen.</li> <li>Automatic: the inlet vent is automatically carried out when the <b>START/STOP</b> key is pressed to stop the test.</li> </ul>	Operator Automatic
Delay (If automatic 'Inlet vent')	To be set (required) Delay = time between test stop and automatic opening of the inlet vent valve. This allows a managed valve to close automatically before inlet vent.	0 – 2 s
Vent timer (If automatic 'Inlet vent')	To be enabled (optional) Activation of the automatic closure of the inlet vent valve.	Enabled Disabled
	To be set Vent timer = time between the opening of the air inlet valve and its automatic closing. This is used to limit the consumption of dry air or nitrogen if the purge is connected.	00'00" – 59'59"

1) Initial setting: see chapter "Tree diagram to the Settings menu"



For quick access from the main screen, configure a function key to **[VENT]** (see chapter "Function keys").



- The **[VENT]** function key is required for the operator to carry out a manual inlet vent (see chapter "Function keys").
- To lock the command for the inlet vent valve, delete the **[VENT]** function key. The icon remains on the main screen as an indicator but manual activation by the operator is disabled.



By connecting an inlet vent (or nitrogen) line to the inlet vent, the detector's tracer gas pollution is reduced.

## 8.2.6 Memo Function

This function freezes the main screen at the end of a test: the last measured leak rate from the test is displayed and flashes.

This function is only available with the 'hard vacuum' test method as soon as the 'gross leak' test mode is reached.

Access: Menu [Test] [Memo Function]		Choice - Setting limit <sup>1)</sup>
Active	To be enabled	No
	Activation of the Memo function	Yes
Display time	To be enabled <ul style="list-style-type: none"> <li>Enabled = the value of the measured leak rate flashes for the set duration.</li> <li>Disabled = the value of the measured leak rate will flash until a new test begins.</li> </ul>	Enabled Disabled
	To be set Display time	00'00" – 59'59"

1) Initial setting: see chapter "Tree diagram to the Settings menu"



For quick access from the main screen, configure a function key to **[MEMO]** (see chapter “Function keys”).

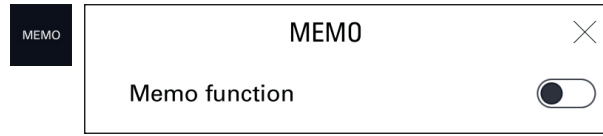

### 8.2.7 Zero activation

This function helps the user to identify very small leak rate variations in the surrounding background noise or to dilate small measured leak rate fluctuations on the analog display.

Access: Menu [Test] [Zero activation]		Choice - Setting limit <sup>1)</sup>
Activation	To be selected <ul style="list-style-type: none"> <li>None: <b>ZERO</b> button inactive</li> <li>Operator: user activation by pressing on the <b>ZERO</b> button, depending on configuration (see below: Zero Exit)</li> <li>Automatic: depending based on configuration (see below: Trigger)</li> </ul>	None Operator Automatic
Zero exit (If operator 'Activation')	To be selected Type of press to exit the function (see below) <ul style="list-style-type: none"> <li>Press once: activate/deactivate zero by quickly pressing the <b>ZERO</b> button.</li> <li>Press &gt; 3s:                             <ul style="list-style-type: none"> <li>activation: quickly press the <b>ZERO</b> button. Each time the key is pressed quickly, a new zero is carried out.</li> <li>deactivation: keystroke &gt; 3 s the <b>ZERO</b> button.</li> </ul> </li> </ul>	Press once Press > 3s
Trigger (If automatic 'Activation')	To be selected Factor for initiating the carrying out of another zero.	Timer Set point
	To be set Initiation value	00'00" – 59'59" (if timer 'Trigger') 1 · 10 <sup>-19</sup> – 1 · 10 <sup>+19</sup> (if set point 'Trigger')

1) Initial setting: see chapter “Tree diagram to the Settings menu”



Using this function is recommended when the background of the tracer gas is stable. This function is used to measure a leak rate that is lower:

- than 2 decades in hard vacuum test mode: 1 · 10<sup>-12</sup> mbar · l/s (1 · 10<sup>-13</sup> Pa · m<sup>3</sup>/s) minimum
- than 2 decades in sniffer mode: 5 · 10<sup>-9</sup> mbar · l/s (5 · 10<sup>-10</sup> Pa · m<sup>3</sup>/s) minimum

than the detector’s background, when the detector is no longer in roughing.

### 8.2.8 Regeneration

This function is used to ‘clean’ the tracer gas from the detector by automatically carrying out a series of short tests and inlet vents between each test. This is used to decrease the background following pollution with tracer gas.

#### NOTICE

##### Risk of pollution

- ▶ Before starting this function, make sure that the leak detector is in an environment free of tracer gas pollution.



For quick access from the main screen, configure a function key to **[REGEN]** (see chapter “Function keys”).





It is recommended to use this function when the background noise of the detector is high

1. Check that the detector is in 'Stand-by' mode.
2. Check that the inlet vent is "automatic."
3. From the Settings screen, press **[Test] [Regeneration]**.
4. Install a blank-off flange on the detector's inlet port.
5. Press **[Start]**.
  - Regeneration stops automatically after 1 hour.
6. To stop regeneration before the automatic stop time, press **[Stop]** or the **START/STOP** key.
  - Start a test ('Zero activation' function not enabled) to check that the detector is no longer polluted.

After regeneration, the inlet vent configuration is the same as it was before regeneration.

### 8.2.9 Massive Mode

This mode allows the detector to perform a test ( $^4\text{He}$  only) on a very large leak when the detector has not shifted to Gross Leak Mode and remains in roughing.

Massive mode can only be used if an external gauge is selected (see chapter "External gauge"):

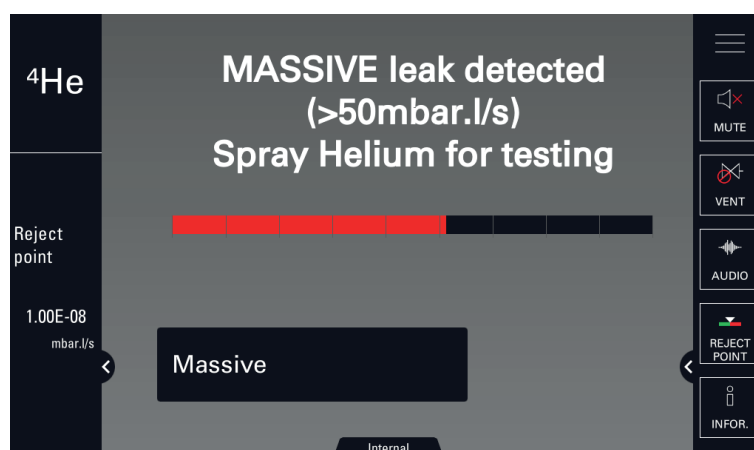

Access: Menu [Test] [Massive Mode]		Choice - Setting limit <sup>1)</sup>
Active	<p>To be selected</p> <p>Prerequisites for the detector to shift automatically into Massive mode:</p> <ul style="list-style-type: none"> <li>• function enabled</li> <li>• pressure &lt; 100 hPa</li> <li>• pressure stabilized for at least 30 s</li> </ul> <p>A message informs the user that the detector has shifted automatically into Massive mode.</p> <p>The detector can then perform a qualitative test of a leak (information leak &gt; 50 mbar · l/s (5 Pa · m<sup>3</sup>/s) only).</p> <p>The maximum use time is 55 minutes.</p>	No Yes
Sensitivity	<p>To be selected</p> <ul style="list-style-type: none"> <li>• High = large volume test (default configuration, recommended)</li> <li>• Low = test on volume &lt; 1 l (if necessary)</li> </ul>	High Low

1) Initial setting: see chapter "Tree diagram to the Settings menu"

### 8.2.10 Calibration check

Calibration check allows the user to save time because this operation is faster than full calibration.

The calibration check is performed with the leak detector's internal calibrated leak (leak type parameter = 'internal').

Calibration check is enabled if the calibration is set to 'Check at start' (see chapter "Calibration function").



This function allows predictive adjustment of the leak rate for repetitive tests where the test time has to be optimized.

The adjustment is made via the RS-232 serial link or logic inputs.



This function provides an adjustment and should not be confused with the correction coefficient.

**This coefficient complements the correction coefficient.**

Access: Menu [Test] [Dynamic calibration]		Choice - Setting limit <sup>1)</sup>
Active	To be enabled Dynamic calibration activation	Enabled Disabled
Value (if 'Active' enabled)	To be set Target value to reach (leak rate value of the installation to calibrate)	$1 \cdot 10^{-19}$ – $1 \cdot 10^{+19}$
Coefficient	Read only Coefficient value calculated during dynamic calibration (coefficient applied if dynamic calibration is enabled)	-

1) Initial setting: see chapter "Tree diagram to the Settings menu"

### Prerequisites

- ▶ Perform leak detector calibration.
- ▶ Enable the correction factor (see chapter "Correction factor") and set it.
- ▶ Activate the dynamic calibration.
- ▶ Set the target value.
- ▶ Assign the logic inputs (see the 37-pin I/O operating instructions (see chapter "Applicable documents")) or connect the RS-232 serial link.

	Logic input	RS-232 serial link command
Start/Stop dynamic calibration coefficient calculation	Dynamic cal.	Start: =CDC Stop: =CDS
Start/Stop Test	HV test	Start: =CYE Stop: =CYD
Start/Stop Memo function	He memo	Start: =MEF Stop: =MER

### Setting procedure for one test

1. Implement the preliminary conditions.
2. Activate the dynamic calibration coefficient calculation.
3. Start a test.
4. Activate the Memo function (logic input or RS-232 serial link command).
  - The new coefficient is automatically calculated and saved.

The coefficient calculated corresponds to the following ratio: target value/displayed leak rate value to be adjusted

The calculated coefficient must be between 0.5 and 3 inclusive. If not, an error message is displayed.
5. Stop the test and deactivate the Memo function (logic input or RS-232 serial link command).
6. Stop the dynamic calibration coefficient calculation.

Example:

- Target value =  $1 \cdot 10^{-7}$
- Value of the leak rate displayed to adjust:  $5 \cdot 10^{-8}$
- Coefficient =  $1 \cdot 10^{-7} / 5 \cdot 10^{-8} = 2$
- As 2 is between 0.5 and 3, the coefficient is correct.

### Setting procedure for several tests

Several tests can be run to calculate the dynamic calibration coefficient. This allows the coefficient value to be fine-tuned.

1. Implement the preliminary conditions.
2. Activate the dynamic calibration coefficient calculation.

3. Start the 1<sup>st</sup> test.
4. Activate the Memo function (logic input or RS-232 serial link command).
  - The new coefficient is automatically calculated and saved.

The 1<sup>st</sup> coefficient (Coef 1) calculated for the 1<sup>st</sup> test corresponds to the following ratio: target value/leak rate value of the 1<sup>st</sup> test

The calculated coefficient must be between 0.5 and 3 inclusive. If not, an error message is displayed.
5. Stop the test and deactivate the Memo function (logic input or RS-232 serial link command).
6. Repeat all of the last 3 operations n times:
  - Start a test
  - Enable the Memo function.
  - Stop the test and disable the Memo function

The calculated and memorized coefficient is readjusted after each test, as in:

$$\text{Coefficient} = \text{Coef } 1 + \text{Coef } 2 + \dots + \text{Coef } n / n$$
7. Stop the dynamic calibration coefficient calculation.



**The coefficient will continue to be readjusted after each test until the dynamic coefficient calibration calculation is stopped.**

### 8.2.13 Purge valve

The purge valve protects the detector from becoming polluted thanks to a continuous air flow inside the vacuum part of the detector.



For a global test of the leak detector, this valve must be closed.

Access: Menu [Test] [Purge valve]		Choice - Setting limit <sup>1)</sup>
Purge valve	Wet model The purge valve is always closed.	-
	Dry Model To be selected <ul style="list-style-type: none"> <li>• Automatic: valve opening/closing managed in the detector's firmware</li> <li>• Closed = valve always closed <sup>2)</sup></li> <li>• Open = valve always open <sup>2)</sup></li> </ul>	Automatic Closed Open
	Integrable model To be selected <ul style="list-style-type: none"> <li>• Closed = valve always closed <sup>2)</sup></li> <li>• Open: valve always open <sup>2)</sup></li> </ul>	Closed Open

1) Initial setting: see chapter "Tree diagram to the Settings menu"

2) Temporary Opening/Closing managed by the detector firmware if necessary, then return to the set status

### 8.2.14 Start-up time delay

The start-up timer prevents the leak detector from being used for a pre-determined duration after it has been switched on.

No measurements can be made if the leak detector is not thermally stabilized, or while traces of tracer gas remain in the detector.

Access: Menu [Test] [Start-up timer]	Choice - Setting limit <sup>1)</sup>
To be set Initiation value	00'00" – 59'59"

1) Initial setting: see chapter "Tree diagram to the Settings menu"



### 8.2.15 Crossover pressures

In hard vacuum test, the user can set the crossover set points to different test modes (see chapter “Test mode”).

Access: Menu [Test] [Crossover pressures]			Choice - Setting limit <sup>1)</sup>
Gross Leak	To be set	Wet and Dry models	$2.5 \cdot 10^{+1} - 1 \cdot 10^{+1}$
	Crossover set point for Roughing in Gross Leak mode	Integrable model	$2.5 \cdot 10^{+1} - 5 \cdot 10^{-1}$
Normal	To be set	Wet and Dry models	$5 \cdot 10^{-1} - 1 \cdot 10^{-1}$
	Crossover set point for Gross Leak mode in Normal mode	Integrable model	$5 \cdot 10^{-1} - 5 \cdot 10^{-2}$

1) Initial setting: see chapter “Tree diagram to the Settings menu”

### 8.3 Configuration menu

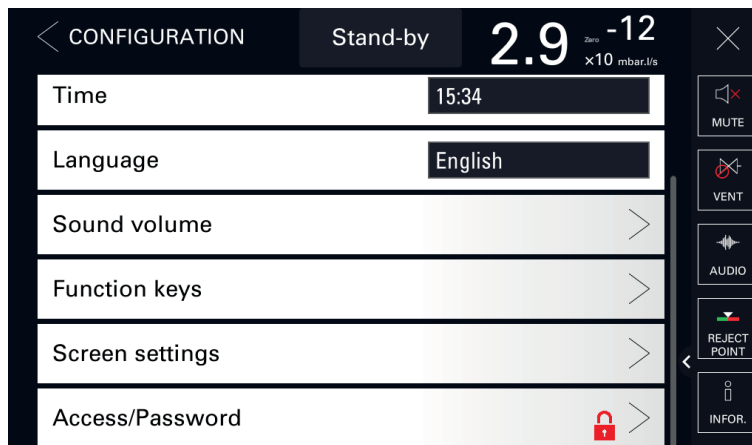
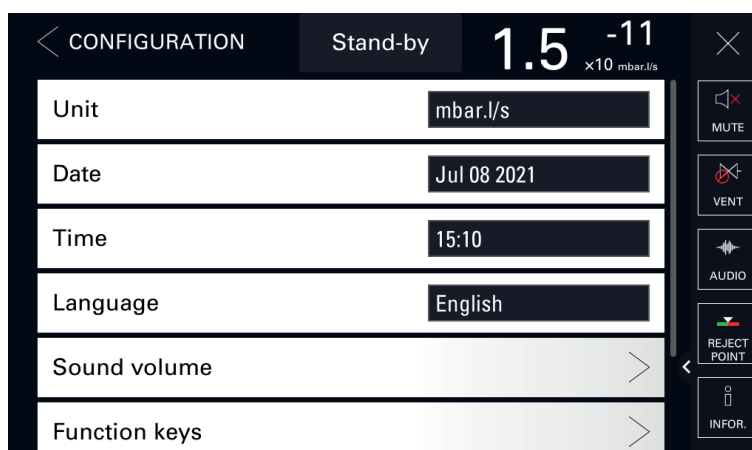

### 8.3.1 Unit - Date - Time - Language

Access: Menu [Configuration]		Choice - Setting limit <sup>1)</sup>
Unit	To be selected <sup>1)</sup>	mbar · l/s Pa · m <sup>3</sup> /s Torr · l/s atm · cc/s ppm sccm sccs mtorr · l/s
Date	To be set <sup>1)</sup>	- Format: mm/dd/yyyy
Time	To be set <sup>1)</sup>	- Format: hh:mm:ss
Language	To be set <sup>1)</sup>	English French German Italian Chinese Japanese Korean Spanish Russian Portuguese

1) No default settings: set by user on switching the detector on for the 1<sup>st</sup> time

### 8.3.2 Sound volume

This menu is used to set the sound volumes for the leak detector.

Access: Menu [Configuration] [Sound Volume]		Choice - Setting limit <sup>1)</sup>
Detector	To be enabled	Enabled
	The audio alarm of the detector informs the user that the reject point has been crossed.	Disabled
	To be set	1 – 9
	Level 9 = 90 dBA	
Voice	To be enabled	Enabled
	The voice of the detector informs the user of the status of the detector or the actions to be carried out.	Disabled
	To be set	1 – 9

1) Initial setting: see chapter “Tree diagram to the Settings menu”

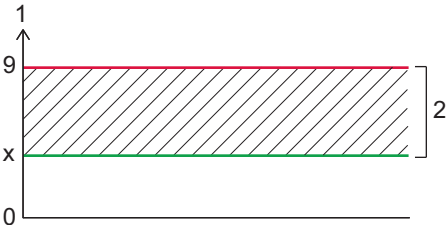
Access: Menu [Configuration] [Sound Volume]		Choice - Setting limit <sup>1)</sup>
Detector min. sound	<p>To be enabled</p> <p>The minimum detector sound defines a minimum level for sounds (see 'Detector' parameter).</p>  <p>1 - Sound range (1–9) 2 - Possible settings range for the sound level (see 'Detector' parameter) x - Minimum detector sound set: no sound will be below x.</p>	Enabled Disabled
	<p>To be set</p> <p>The 'Detector' parameter values are automatically corrected if the minimum detector sound is greater than the set values.</p> <p>The 'Detector' parameter values are retained if the minimum detector sound is lower than the set values.</p>	1 – 9

1) Initial setting: see chapter "Tree diagram to the Settings menu"



For quick access from the main screen, use the **[AUDIO]** function key.

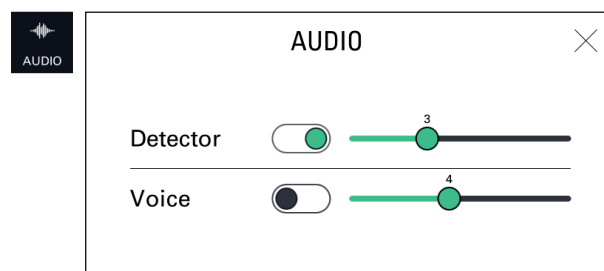

To quickly turn off the sound of the detector and the sniffer probe, use the **[MUTE]** function key.



The red cross on the pictogram indicates that the "Mute" function is enabled.

### 8.3.3 Function keys

The function keys are used to view settings, access a menu (shortcut) or start a direct action. An enabled function key is available in the function keys bar (see chapter "Function keys bar").

Access: Menu [Configuration] [Function keys]		Choice - Setting limit <sup>1)</sup>
Timer	Enable for each function key	Enabled
Audio	Function key display in the function keys bar	Disabled
Cor.	16 function keys are offered but only a maximum of 15 can be made available (enabled) in the function keys bar. The 16 <sup>th</sup> function key is greyed out. To enable it, disable another function key first.	
Mute		
Reject point		
Infor.		
Tracer gas		
Vent		
Method		
Mode		
Memo		
Paging		
Regen		
Cal type		
Screen Shot		
Switch Set point		

1) Initial setting: see chapter "Tree diagram to the Settings menu"

### 8.3.4 Screen settings

This menu is used to enter the control panel settings.

Access: Menu [Configuration] [Screen settings]			Choice - Setting limit <sup>1)</sup>
Brightness	To be set		0 – 20
Paging Function	Function available only if a wireless remote control is detected. To be selected When a wireless remote control (accessory) is used, the 'Paging' function makes it possible to easily find the remote if it is located within its field of use with the detector. When the function is activated, the remote control emits a sound signal so it can be located. To stop the sound signal, deselect the Paging function. Function key: see below.		Enabled Disabled
Leak rate bar-graph	See details below		-
Application windows	Std-by Value	To be selected Leak rate display in 'Stand-by' mode	Hide Show
	Show inlet pressure	To be selected Inlet pressure display.	Hide Show
	Show second pressure	To be selected Display of the cell pressure or of an external gauge. <ul style="list-style-type: none"> <li>• None: no display</li> <li>• Cell.: analyzer cell pressure display</li> <li>• Ext.: external gauge pressure display (at the customer's expense)</li> </ul> The external gauge (at the customer's expense) is a gauge installed on the customer's application, connected to the 37-pin I/O board.	None Cell. Ext.
	Show synoptic	To be selected Synoptic display (see chapter "Navigation").	Hide Show
Reset screen parameters	Function launching This function is used to load the default settings of the control panel.		-

1) Initial setting: see chapter "Tree diagram to the Settings menu"



For quick access from the main screen, configure a function key to **[PAGING]** (see chapter "Function keys").



### Leak rate bargraph details

This menu is used to enter the bargraph settings.

Access: Menu [Configuration] [Leak rate bargraph]		Choice - Setting limit <sup>1)</sup>
Zoom on set point	To be enabled Zoom on set point is used to display on the bargraph the reject set point centered on 2 decades.	Enabled Disabled
High decade	To be set High decade (max) of the bargraph	-12 – +6
Low decade	To be set Low decade (min) of the bargraph	-13 – +5
Lower display limit	To be set This limit defines the lower display limit for the measured leak rate. The measured leak rate is not displayed if it is lower than the set lower display limit.	$1 \cdot 10^{-13} - 1 \cdot 10^{+06}$
Show 2 <sup>nd</sup> digit	To be enabled Display of a second digit after the decimal point for digital display of the leak rate	Enabled Disabled

1) Initial setting: see chapter "Tree diagram to the Settings menu"

### 8.3.5 Access - Password

This menu is used to manage the access rights to the various menus and/or screens.

Regardless of the user level, a password is required to access this menu.

The default password is 5555.



The password is not saved in the control panel. If the password is forgotten, it can be found using the RS-232: see RS-232 operating instructions.

Access: Menu [Configuration] [Access/Password] + password		Choice - Setting limit <sup>1)</sup>
User level	To be selected 3 user levels can be used to restrict the display and access to settings and functions. See details below	Restricted access Medium access Full access
Password	To be set This function is used to block access to one or more Settings menus. To access a locked menu, the user will be asked to provide the password.	-
Customized access	To be set Access to certain items may be permitted or prohibited. See details below	-

1) Initial setting: see chapter "Tree diagram to the Settings menu"

#### User level and customized access

The rights defined in the 2 tables below are the **default** rights for each user level.

These rights can be customized: they can be assigned/withdrawn (see chapter "Access - Password").

	User level		
	Restricted access	Medium access	Full access
<b>START/STOP, CAL, ZERO</b> buttons	Invalid No settings can be made without a password	Valid	
6 setting menus	Invalid No setting possible without a password (temporary access allowed)	Valid	
Function keys	<ul style="list-style-type: none"> <li>• Hidden except for <b>[VENT]</b> and <b>[MUTE]</b></li> <li>• Displayed if padlock removed (customized access)</li> </ul>		Displayed

#### Temporary access to a locked menu

To access a locked menu, the user is asked to provide the password.

Temporary access: after returning to the main screen, the menu is once again locked.

1. Access the Settings menu
2. Press **[Configuration] [Access/Password]**.
3. Enter password.

#### Access to the graph screen, menus and locked functions

Access to the following items may be permitted or prohibited:

- graph screen
  - settings menus: Measurement, Test, Configuration, Maintenance, File Manager and Advanced
  - function keys: [AUDIO], [COR.], [MUTE], [REJECT POINT], [INFOR.], [TIMER] and [TRACER GAS]
1. Access the menu **[Access/Password]**.
  2. Press **[Configuration] [Access/Password]** + password + **[Customized access]**.
  3. Press the padlock to lock/unlock.
    - The presence of an open green padlock indicates that access to the item is permitted (unlocked).
    - The presence of a closed red padlock indicates that access to the item is prohibited (locked).

#### Customizing user levels

Depending on the user level, access to the following items may be permitted or prohibited:

- graph screen
- settings menus: Measurement, Test, Configuration, Maintenance, File Manager and Advanced
- function keys: [AUDIO], [COR.], [MUTE], [REJECT POINT], [INFOR.], [TIMER] and [TRACER GAS]

It is possible to customize the rights for each user level.

1. Select the user level to customize.
2. Press **[Configuration] [Access/Password]** + password + **[Customized access]**.
3. Press the padlock of the item to allow/deny access.
  - a green padlock indicates that access to the item is permitted.
    - If the item is a function key, the function key is added to the function key bar.
  - a red padlock indicates that access to the item is prohibited.
    - If the item is a function key, the function key is removed from the function key bar.
4. Repeat the operation for each user level to be customized.

## 8.4 Maintenance menu

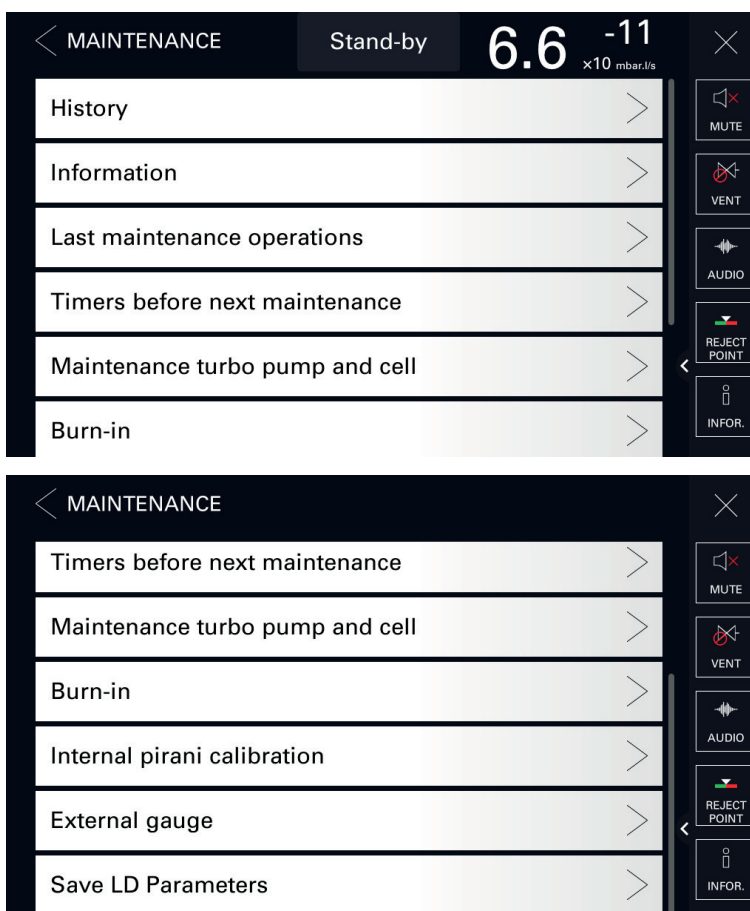

### 8.4.1 History

This function is used to view the event and calibration histories.

#### Events history

An event can be an error (Exxx), a warning (Wxxx) or information (Ixxx).

The events history records the events that have occurred.

Access: Menu **[Maintenance] [History] [Events history]**

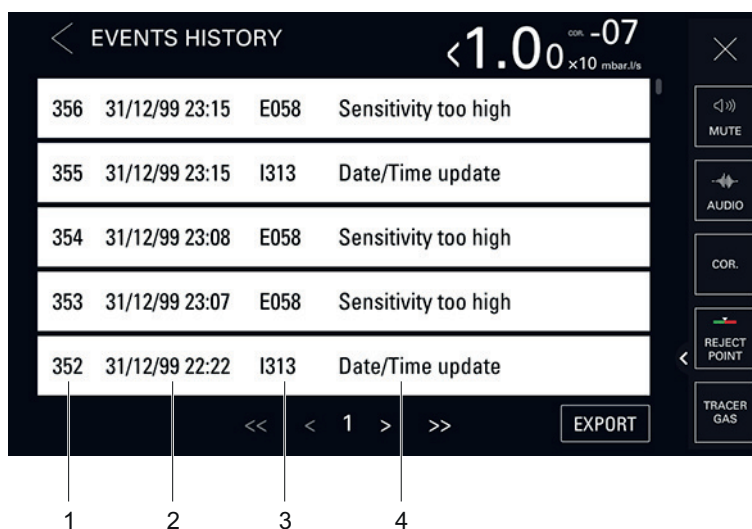

1 Chronological event number  
2 Date and time of the event

3 Code for the event  
4 Description of the event

Information coding:

Code	Event	Description
I300	Air inlet	Inlet vent
I301	Stop on pollution	Test stops automatically if measured leak rate pollution > Pollution
I302	Reset timer backing pump	Backing pump timer reset
I303	Reset timer turbo pump 1	Secondary pump 1 hour timer reset
I306	Reset timer filament #1	Filament 1 hour timer reset
I307	Reset timer filament #2	Filament 2 hour timer reset
I308	Reset cycles counter	Cycle timer reset
I309	Emission increase	<sup>4</sup> He, Mass 3: change in emission intensity (Ie) <sup>2</sup> H: change in emission intensity (Ie)
I310	Calibration restart	Automatic start of a new calibration
I311	Detector stop	Shutdown the detector
I312	Detector start	Start-up of the detector
I313	Date/Time update	Date or time modification
I314	Cell firmware update	Analyzer cell firmware update
I315	CPU firmware update	Detector firmware update
I316	LCD firmware update	Control panel firmware update
I317	Voice update	Voice update
I318	Full parameters reset	Complete detector parameter reset
I319	Filament change	Filament change from the Maintenance menu
I321	Storage delay	Detector switched off for 15 days (minimum)

**Calibrations history**

The calibrations history records the calibrations made.

Access: Menu [Maintenance] [History] [Calibrations history]

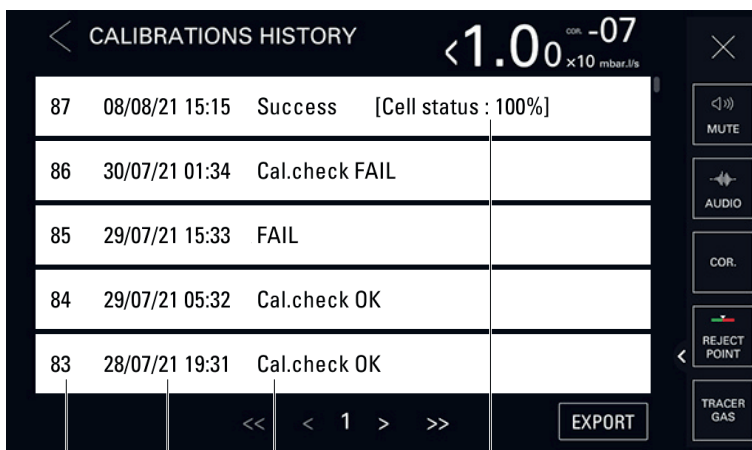

- 1 Chronological calibration number
- 2 Date and time of the calibration
- 3 Calibration result (see below)
- 4 Indicator of analyzer cell performance (see below)



Result	Description
Success [Cell status: xxx %]	Calibration success [Cell status: xxx %] Indicator of analyzer cell performance. Default settings: between 90% and 100% Normal operation: between 10% and 100% Normal wear on some cell components will reduce this value over time but will not reduce the accuracy of the detector's measurements.
FAIL	Calibration failure
Cal. check OK	Calibration check successful
Cal. check FAIL	Calibration check failure

### History export

An export can be generated containing the event **and** calibration history.

2 possible modes of access:

- **[Maintenance] [History] [Events history]**
- **[Maintenance] [History] [Calibrations history]**

1. Insert a USB stick into the control panel.
2. Press **[Export]**.

The message "Events and calibrations exported" is displayed to confirm the export.

## 8.4.2 Information

This function is used to view information on the leak detector.



For quick access from the main screen, use the **[INFOR.]** function key.

DETECTOR INFORMATION	
Date & Time	Jul 09 2021 09:12
v.LC4	L0476 V1.2r14 (B44)
v.CPX	L0379 V3.9r30 9E1E
v.CEN	L0264 V3.3r55 FDAFAD91
Tracer gas	<sup>4</sup> He
P Inlet	1.10e-00 mbar
Reject point / Warning point	1.00e-08 / 20 %
Method	Hard vacuum
Mode	Normal
Calibration	Operator [Internal]
Last calibration	Jan 01 2021 00:00 Ok
Filament	1 (On)
Cell status	100 %
Next maintenance	14333 h

### Detector information

Reminder: for viewing only in this menu

#### Access: Menu [Maintenance] [Information] [Detector]

Timer	Running time for detector
Date and time	Date and time
Software release .LC4	Control panel firmware information
Software release .CPX	Leak detector firmware information
Software release .CEN	Analyzer cell firmware information
Inlet pressure	Inlet pressure
Reject point	Set reject point
Warning point	Warning point set
Correction	Correction factor status
Tracer gas	Tracer gas selected
Filament	Filament selected

## Settings menu

### Access: Menu [Maintenance] [Information] [Detector]

Cell status	Status of the cell
Method	Test method set
Mode (if 'hard vacuum' method)	Test mode selected
Probe type (if 'sniffer' method)	Type of probe selected
Calibration	Calibration set
Last calibration	Time since the last calibration performed
Next maintenance	Time before the next maintenance to be performed



For quick access from the main screen, use the **[TIMER]** function key.

TIMERS	
Detector	335 h
Filament #1	322 h
Filament #2	1 h
Cycles counter	137
Backing pump	2867 h
Turbo pump	324 h
Next maintenance	14333 h

### Analyzer cell information

Reminder: for viewing only in this menu

### Access: Menu [Maintenance] [Information] [Analyzer cell]

Filament selected	Read only Filament selected for the measurement (2 filaments in the analyzer cell).
Filament	Read only Status of filament selected (on/off)
Cell status	Read only Performance indicator of the analyzer cell for the selected filament. <ul style="list-style-type: none"> <li>• Default settings: between 90% and 100%</li> <li>• Normal operation: between 10% and 100%</li> </ul> Normal wear on some cell components will reduce this value over time but will not reduce the accuracy of the detector's measurements.
Triode pressure	Read only For Service Centers only.
Electronic zero	Read only For Service Centers only.
Target value	Read only (see chapter "Target value")
Acceleration voltage	Read only For Service Centers only.
Emission measurement	Read only For Service Centers only.
Sensitivity coefficient	Read only For Service Centers only.
Cell temperature	Read only The temperature at the analyzer cell
Timer filament 1	Read only Running time for filament 1 Function to be started <ol style="list-style-type: none"> <li>1. Press the running time for filament 1.</li> <li>2. Press <b>[Reset timer]</b> to reset the timer.</li> </ol>

**Access: Menu [Maintenance] [Information] [Analyzer cell]**

Timer filament 2	Read only Running time for filament 2
	Function to be started 1. Press the running time for filament 2. 2. Press <b>[Reset timer]</b> to reset the timer.

**Backing pump information****Access: Menu [Maintenance] [Information] [Backing Pump]**

Timer backing pump	Press <b>[&gt;]</b> to display the details.
	Read only Running time for backing pump
Status	Read only Pump status
Speed	Read only Pump at set operating speed

**Turbomolecular pump information****Access: Menu [Maintenance] [Information] [Turbo pump]**

Timer turbo pump	Press <b>[&gt;]</b> to display the details.
	Read only Running time for turbomolecular pump
Status	Read only Pump status
Speed	Read only Pump at set operating speed

**8.4.3 Last maintenance operations**

This function displays the last maintenance operations performed on the detector and recorded by the service technician.

The message “No maintenance done” is displayed if no maintenance has been recorded.

Reminder: for viewing only in this menu

**Access: Menu [Maintenance] [Last maintenance operations]**

Date	Date of the maintenance work
Inspector name	Maintenance technician who performed the work
Number total hours	Number of hours of detector operation at the time of maintenance
Comments	Comment entered by the service technician

**8.4.4 Counters before next maintenance**

This function displays the remaining periods before the next maintenance.

Reminder: for viewing only in this menu

**Access: Menu [Maintenance] [Counters before next maintenance]**

Valves	Number of cycles completed versus number of cycles before next maintenance
Backing pump	Number of hours of backing pump operation versus the number of hours before the next maintenance
Turbo pump	Number of hours of turbomolecular pump operation versus the number of hours before the next maintenance

## 8.4.5 Maintenance turbo pump and cell

Access: Menu [Maintenance] [Maintenance turbo pump and cell ]		Choice - Setting limit <sup>1)</sup>
Filament	To be selected Filament selected for the measurement (2 filaments in the analyzer cell).	Filament 1 Filament 2
Stop and vent	Function to be started This function is used to shut down the secondary pump and to perform an inlet vent so that the secondary pump and the analyzer cell are at atmospheric pressure. See below	-

1) Initial setting: see chapter "Tree diagram to the Settings menu"

### Stop and vent

To carry out maintenance on a vacuum circuit component, the vacuum circuit of the detector must be at atmospheric pressure.

1. Press **[Stop and vent]**.
  - The turbomolecular pump slows to a speed that allows venting.
  - A message notifies the user when the leak detector can be shut down.
  - If the user does not wish to stop the detector, press **[Restart leak detector]**. The detector start-up screen is displayed.
2. Stop the leak detector.
3. Wait until the control panel turns off completely and unplug the main power supply cable before working on the detector.

## 8.4.6 Burn-in

This function is used to prepare the detector, leaving it in optimal working condition by automatically carrying out a series of short tests and inlet vents between each test.

### NOTICE

#### Risk of pollution

- ▶ Before starting this function, make sure that the leak detector is in an environment free of tracer gas pollution.

Access: Menu [Maintenance] [Burn-in]

Inlet vent	Only available if the inlet vent is set to 'Operator'. Access the 'Inlet vent' menu From the 'Inlet vent' menu, return to the 'Burn-in' menu by pressing [ <b>&lt;</b> ].
Start without calib.	Function to be started Function launching Series of tests and inlet vents
Start with calibration	Function to be started Test runs, inlet vents and calibrations Available in hard vacuum test only
Stop	Stop burn-in in progress

### Prerequisites

- Detector in 'Stand-by' mode
- "Automatic" inlet vent selected

### Procedure

1. Implement the preliminary conditions.
2. Install a blank-off flange on the detector's inlet port.
3. Press **[Start without calib.]** or **[Start with calib.]**.
4. Press **[Stop]** or the **START/STOP** button to stop the burn-in.

## 8.4.7 Internal Pirani gauge calibration

This function is used to calibrate the detector's Pirani internal gauge.

Access: Menu [Maintenance] [Internal Pirani calibration]	
Pressure	Read only Limit pressure or atmospheric pressure display depending on the procedural step. <ul style="list-style-type: none"> <li>• Pressure <math>\approx</math> 5000 -&gt; Limit pressure display</li> <li>• Pressure <math>\approx</math> 30000 -&gt; Atmospheric pressure display</li> </ul>
Inlet pressure	Read only Inlet pressure display.
HV valid	Function launching Setting the limit pressure ( $\approx$ 5000)
Hard Vacuum	Displaying the limit pressure
Atm valid	Function launching Setting the atmospheric pressure ( $\approx$ 30000)
Atmospheric	Displaying the atmospheric pressure
Start/Stop	Function launching Test start
Inlet vent	Function launching

### Prerequisites

- Hard vacuum test method selected
- Most sensitive test mode selected
- Manual cycle end (= 'operator' selected).

### Procedure

The calibration involves setting the limit pressure then the atmospheric pressure.

The pressures displayed at the different steps are indicated in the table below.

1. Implement the preliminary conditions.
2. Put the leak detector on 'Stand-by' mode (step 1).
3. Close the detector's inlet with a blank-off flange.
4. Create an inlet vent: press **[VENT]**.
5. Wait 5 minutes.
6. Press **[Valid Atm]** (step 2).
7. Start a test: press **[Start]** on the menu or the **START/STOP** button.
8. Wait 5 minutes for the measurement to stabilize (step 3).
9. Press **[Valid HV]** (step 4).
10. Start the test: press **[Stop]** on the menu or the **START/STOP** button.

Pressures displayed during the procedure

	Pressures displayed at the different steps in the procedure			
	Step 1	Step 2	Step 3	Step 4
Pressure	<b>P<sub>1</sub></b> ( $\approx$ 30000)	<b>P<sub>1</sub></b> ( $\approx$ 30000)	<b>P<sub>2</sub></b> ( $\approx$ 5000)	<b>P<sub>2</sub></b> ( $\approx$ 5000)
Inlet pressure	$1 \cdot 10^{-3}$	$1 \cdot 10^{-3}$	$1 \cdot 10^{-3}$	$1 \cdot 10^{-3}$
Limit pressure (HV)	<b>V</b> ( $\approx$ 5000)	<b>V</b> ( $\approx$ 5000)	<b>V</b> ( $\approx$ 5000)	<b>P<sub>2</sub></b> ( $\approx$ 5000)
Atmospheric pressure (Atm)	<b>A</b> ( $\approx$ 30000)	<b>P<sub>1</sub></b> ( $\approx$ 30000)	<b>P<sub>1</sub></b> ( $\approx$ 30000)	<b>P<sub>1</sub></b> ( $\approx$ 30000)

P: pressure value

V: limit pressure value (HV)

A: atmospheric pressure value (Atm)

## 8.4.8 External gauge

This function is used to manage the leak detector by an external gauge.

**Prerequisites**

- Detector equipped with a 37-pin I/O communication interface (see chapter “Accessories”)
- Massive Mode disabled
- Inlet pressure source: external
- Possible gauges

		Type of gauge detected by the detector	Gauge model
Linear gauge	Capacitive	Linear	CMRxxx
	Piezo	Linear	APRxxx
Logarithmic gauge	Pirani	TPR/PCR	TPRxxx
	Capacitive Pirani	TPR/PCR	PCRxxx

3 cables (3/10/20 m) available as accessories (see chapter “Accessories”)  
 The gauge and the connection cable are the customer’s responsibility.

Access: Menu [Maintenance] [External gauge]		Choice - Setting limit <sup>1)</sup>
Gauge	To be selected External gauge model	None TPR/PCR Linear
External Pressure (mbar)	Read only Pressure measured by the external gauge	-
P. Inlet Source	To be selected Inlet pressure displayed on the main screen: <ul style="list-style-type: none"> <li>• Internal: internal leak detector gauge</li> <li>• External: external gauge on the customer’s installation</li> </ul>	Internal External
Full scale (mbar) (if “Linear”)	To be set Set the operating range for the gauge: value indicated on the gauge	0.1 – 5000

1) Initial setting: see chapter “Tree diagram to the Settings menu”

### 8.4.9 Saving/Loading of the detector parameters

**Saving of parameters**

This function is used to save the following detector parameters:

- all of the parameters set in the “Settings” chapter.
- all of the parameters set in the “Graph screen: graph parameters” chapter.

Access: Menu [Maintenance] [Save LD Parameters] [Save LD Parameters]

The file manager opens (see chapter “File manager menu” of the operating instructions).

1. Press [Internal Memory] or [USB Stick] to select the desired location.
2. Rename the file, if necessary.
  - The created backup file is called “Setting” by default.
3. Press [Save].
  - The backup file is a .CF4. file.

**Loading of parameters**

This function is used to load the previously saved detector parameters.

Access: Menu [Maintenance] [Save LD Parameters] [Load LD Parameters]

The file manager opens (see chapter “File manager menu” of the operating instructions).

1. Press [Internal Memory] or [USB Stick] to select the desired location.
2. Select the backup file to be loaded (.CF4).
3. Press [Open].

## 8.5 File Manager menu

This function is used to manage saved files:

- in the detector’s internal memory,
- on a USB stick.



### Type of USB stick

All commercial USB sticks with a FAT 32 format can be used (32 GB max.).

**Promotional USB sticks are prohibited:** they are not reliable.

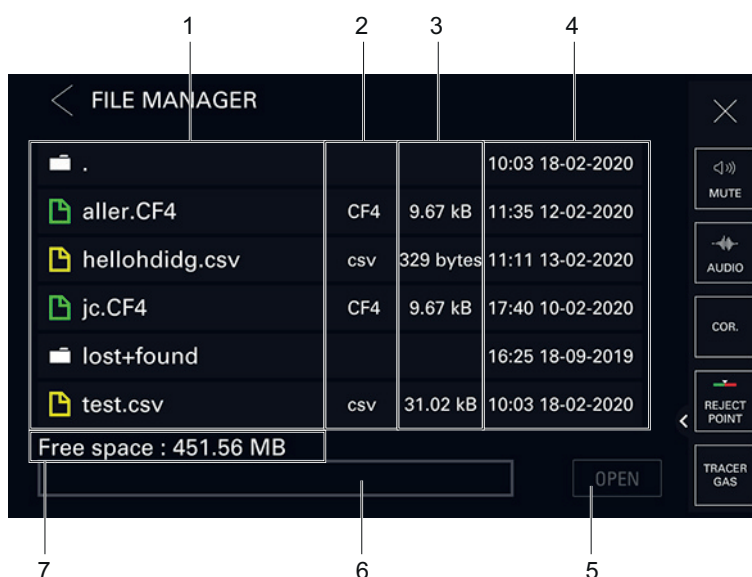
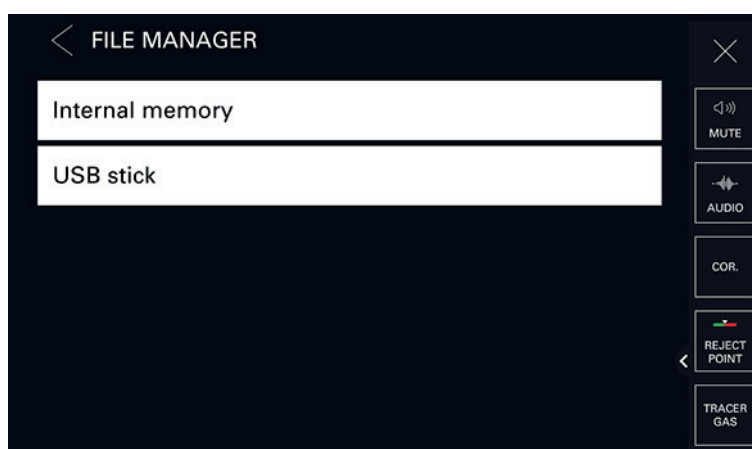

- |  |   |
|--|---|
| 1 Folder and/or file saved                           | 4 Navigation tools  |
| 2 Date and time saved                                | 5 Memory size available in the selected medium (USB stick or internal memory) |
| 3 Button for opening the selected file <b>[OPEN]</b> |   |

### Access to data

1. Insert the USB stick if necessary.
2. Press **[Internal Memory]** or **[USB Stick]** to select the desired medium.  
The list of available folders and/or files is displayed.
  - a Double click on a folder to access its contents.
  - b Select the file to view.
  - c Press **[OPEN]** to display it.

**Access to 'navigation' and 'edit' modes**

1. Press an item (folder or file). It will be highlighted in red.  
In 'navigation' mode, any selected item is highlighted in red.
2. Press this item (folder or file) until it is highlighted in green. The 'edit' mode is enabled.  
In 'edit' mode, any selected item is highlighted in green.  
Possible actions in 'edit' mode:
  - Press **[DELETE]** to delete the selected item.
  - Press **[RENAME]** to rename the selected item.
  - Press **[MOVE TO]** to move the selected item.
3. Press an item (folder or file) until it is highlighted in red. The 'edit' mode is disabled, the 'navigation' mode is enabled.  
In 'navigation' mode, any selected item is highlighted in red.

**8.6 Advanced menu**

Advanced functions reserved for specific uses of the detector (advanced settings requiring proper knowledge of leak detection).

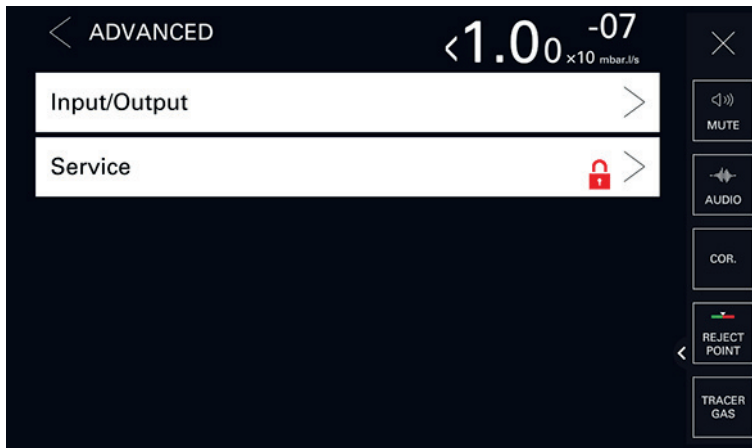

**8.6.1 Input/Output**

**Serial link 1 and serial link 2**

The parameters displayed depend on the choices made.

Access: Menu [Advanced] [Input/Output] then [Serial link 1] or [Serial link 2]		Choice - Setting limit
Type	To be selected Type of link according to its use: see the operating instructions of the accessory/ option to be used.	Serial <sup>2)</sup> Not used <sup>3)</sup> USB <sup>3)</sup>
Mode	To be selected Link mode according to its use: see the operating instructions of the accessory/ option to be used.	Basic Spreadsheet Advanced Export Data RC 500 WL RC 500 HLT 5xx HLT 2XX Ext. module
Period <sup>4)</sup>	To be set	0 s – 24 h

1) Default settings: see chapter "Tree diagram of the Settings menu"

2) Serial link 1 only

3) Serial link 2 only

4) 'Spreadsheet' mode only



Access: Menu [Advanced] [Input/Output] then [Serial link 1] or [Serial link 2]		Choice - Setting limit
Handshake	To be selected	Yes No
Module <sup>3)</sup>	Read only	-
Name <sup>3)</sup>	Read only	-
Power pin 9 <sup>2)</sup>	Read only	5 V

1) Default settings: see chapter "Tree diagram of the Settings menu"

2) Serial link 1 only

3) Serial link 2 only

4) 'Spreadsheet' mode only

#### I/O connector

Access: Menu [Advanced] [Input/Output] [I/O connector]

According to configuration upon order, the detector is equipped with:

- a 15-pin D-Sub I/O interface
- a Profibus and 15-pin D-Sub I/O interface
- a 37-pin D-Sub I/O interface (with USB)
- an Ethernet and 37-pin D-Sub I/O interface (with USB)
- a Profinet and 15-pin D-Sub I/O interface

Refer to the interface operating instructions (see chapter « Applicable documents »)

## 8.6.2 Service

Access to the Service menu is password protected.

Reserved for the Service Centers.

## 9 Maintenance/Replacement

### **Maintenance intervals and responsibilities**

The detector maintenance operations are described in the Maintenance instructions for the detector.

The manual specifies:

- maintenance intervals,
- maintenance instructions,
- shutting the product down,
- tools and spare parts.

## 10 Accessories

Accessory	Description	Part Number
RC 10 WL remote control (wireless)	-	124193
Standard sniffer probe	-	Refer to Pfeiffer Vacuum catalogue
Standard sniffer probe extension	Length 10 m	090216
Smart sniffer probe	With 3 m connection cable	BG 449 207 -T
	With 5 m connection cable	BG 449 208 -T
	With 10 m connection cable	BG 449 209 -T
Calibrated leaks	Tracer gas: 100% <sup>4</sup> He	Refer to Pfeiffer Vacuum catalogue
Adaptor for external calibrated leak/sniffer probe	DN 25 ISO-KF	110716
	DN 16 ISO-KF	110715
Spray gun	Standard model	112535
	Elite model	109951
Communication interface	37-pin input/output - USB	121350S
	37-pin input/output - USB - Ethernet	121352S
	Profibus V2 - 15-pin input/output	127447S
	Profinet - 15-pin input/output	127448S
ECB Wi-Fi external communication box	-	125902
Inlet filters	Available in bronze or stainless steel, 5 to 20 µm mesh	Contact us
By-Pass Kit (37-pin I/O communication interface required)	Europe model	PT 445 411 -T
	US model	PT 445 413 -T
Exhaust connector for external OME DN 25 ISO-KF (Wet model only)	-	122405
External gauge (37-pin I/O communication interface required)	CMRxxx / APRxxx / TPRxxx / PCRxxx model	Refer to Pfeiffer Vacuum catalogue
HLT I/O compatibility module	-	122742
Cart	2 wheels <sup>1)</sup>	122570
	4 wheels 100-110 V~ - 50/60 Hz	805142
	4 wheels -	805143
	200-240 V~ - 50/60 Hz	
Cables for connecting detector/external gauge (for CMRxxx / APRxxx / TPRxxx / PCRxxx model)	Length 3 m	A333746
	Length 10 m	A333747
	Length 20 m	A333748

1) Integrable model: external pumping cannot be installed on this type of cart.

# 11 Technical data and dimensions

## 11.1 General

Databases of technical characteristics of Pfeiffer Vacuum leak detectors:

- Technical characteristics according to:
  - AVS 2.3: Procedure for calibrating gas analyzers of the mass spectrometer type
  - EN 1518: Non-destructive testing. Leak testing. Characterization of mass spectrometer leak detectors
  - ISO 3530: Methods of calibrating leak detectors of the mass-spectrometer-type used in the field of vacuum technology
- Standard conditions: 20 °C, 5 ppm <sup>4</sup>He ambient conditions, degassed detector
- Zero function or background suppression enabled
- Acoustic pressure level: distance in relation to the detector 1 m.

## 11.2 Technical characteristics

Parameters	ASM 340 Wet model	ASM 340 Dry Model	ASM 340 Integrable model
Connection flange (inlet)	DN 25 ISO-KF	DN 25 ISO-KF	DN 25 ISO-KF
Flow rate for He	2.5 l/s	2.5 l/s	2.5 l/s
Backing pump capacity	15 m <sup>3</sup> /h	3.4 m <sup>3</sup> /h	According to customer backing pump
Start-up time (20 °C) without calibration	~ 3 min	~ 3 min	-
Sound level	54 dB(A)	52 dB(A)	54 dB(A)
Protection type	IP 20	IP 20	-
Max. power consumption	850 W	600 W	350 W
Maximum test pressure	25 hPa	25 hPa	25 hPa <sup>1)</sup>
Weight	56 kg	45 kg	32 kg
Detectable gases	<sup>4</sup> He, Mass 3, H <sub>2</sub>	<sup>4</sup> He, Mass 3, H <sub>2</sub>	<sup>4</sup> He, Mass 3, H <sub>2</sub>
Test method	Hard vacuum and sniffer	Hard vacuum and sniffer	Hard vacuum and sniffer
Minimum detectable leak rate for helium (sniffer leak detection)	5 · 10 <sup>-9</sup> atm cc/s (5 · 10 <sup>-10</sup> Pa m <sup>3</sup> /s)	5 · 10 <sup>-9</sup> atm cc/s (5 · 10 <sup>-10</sup> Pa m <sup>3</sup> /s)	5 · 10 <sup>-9</sup> atm cc/s (5 · 10 <sup>-10</sup> Pa m <sup>3</sup> /s)
Minimum detectable leak rate for helium (hard vacuum leak detection)	1 · 10 <sup>-12</sup> atm cc/s (1 · 10 <sup>-13</sup> Pa m <sup>3</sup> /s)	1 · 10 <sup>-12</sup> atm cc/s (1 · 10 <sup>-13</sup> Pa m <sup>3</sup> /s)	1 · 10 <sup>-12</sup> atm cc/s (1 · 10 <sup>-13</sup> Pa m <sup>3</sup> /s)
Power supply <sup>2)</sup>	100-110 V~ 50/60 Hz 200-240 V~, 50/60 Hz	100-240 V~ 50/60 Hz	100-240 V~ 50/60 Hz

1) Between 25 hPa and 5 hPa, qualitative measurement only.

2) According to IEC/UL/CSA regulations, products can withstand a supply voltage variation of ± 10%.

### Environmental conditions

Parameters	ASM 340 Wet model	ASM 340 Dry Model	ASM 340 Integrable model
Use temperature (in hard vacuum test)	0–45 °C	0–35 °C	0–45 °C <sup>1)</sup>
Use temperature (sniffer)	0–40 °C	0–35 °C	0–40 °C
Storage temperature	-20–+55 °C		

1) If ultimate vacuum of backing pump < 5 · 10<sup>-2</sup> hPa. Otherwise, 0–40 °C

Parameters	ASM 340 Wet model	ASM 340 Dry Model	ASM 340 Integrable model
Maximum air humidity	85%, non-condensing		
Maximum magnetic field	3 mT		
Pollution degree	Level 2		
Maximum altitude above sea level	2000 m		
Use	Indoor use only		
Penetration protection rating	IP 20		
Network overvoltage level	Category II		

1) If ultimate vacuum of backing pump <math>5 \cdot 10^{-2}</math> hPa. Otherwise, 0–40 °C

### 11.3 Units of pressure

Unit	mbar	bar	Pa	hPa	kPa	Torr / mm Hg
mbar	1	$1 \cdot 10^{-3}$	100	1	0.1	0.75
bar	1000	1	$1 \cdot 10^5$	1000	100	750
Pa	0.01	$1 \cdot 10^{-5}$	1	0.01	$1 \cdot 10^{-3}$	$7.5 \cdot 10^{-3}$
hPa	1	$1 \cdot 10^{-3}$	100	1	0.1	0.75
kPa	10	0.01	1000	10	1	7.5
Torr / mm Hg	1.33	$1.33 \cdot 10^{-3}$	133.32	1.33	0.133	1

1 Pa = 1 N/m<sup>2</sup>

Tbl. 1: Units of pressure and their conversion

### 11.4 Gas throughputs

Unit	mbar l/s	Pa m <sup>3</sup> /s	sccm	Torr l/s	atm cm <sup>3</sup> /s
mbar l/s	1	0.1	59.2	0.75	0.987
Pa m <sup>3</sup> /s	10	1	592	7.5	9.87
sccm	$1.69 \cdot 10^{-2}$	$1.69 \cdot 10^{-3}$	1	$1.27 \cdot 10^{-2}$	$1.67 \cdot 10^{-2}$
Torr l/s	1.33	0.133	78.9	1	1.32
atm cm <sup>3</sup> /s	1.01	0.101	59.8	0.76	1

Tbl. 2: Gas throughputs and their conversion

### 11.5 Dimensions

(mm)

**Wet and Dry models**

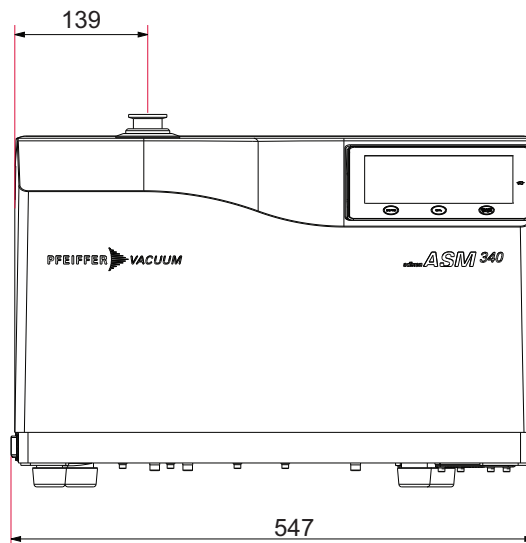
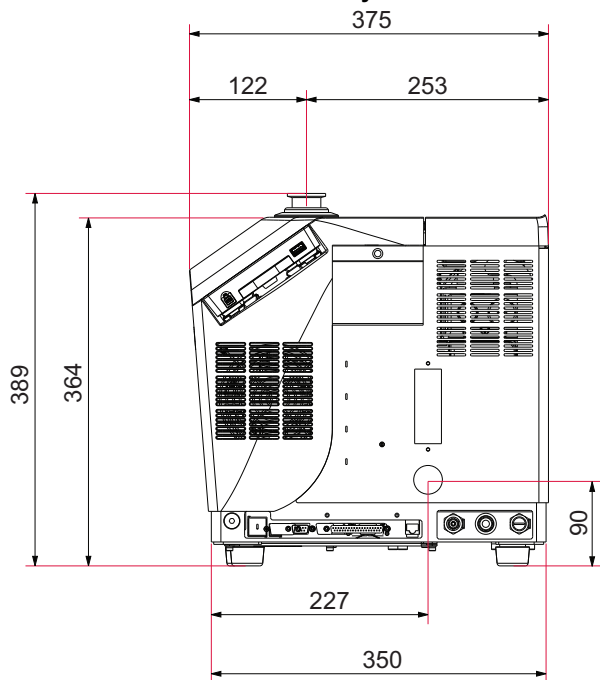

**Integrable model**

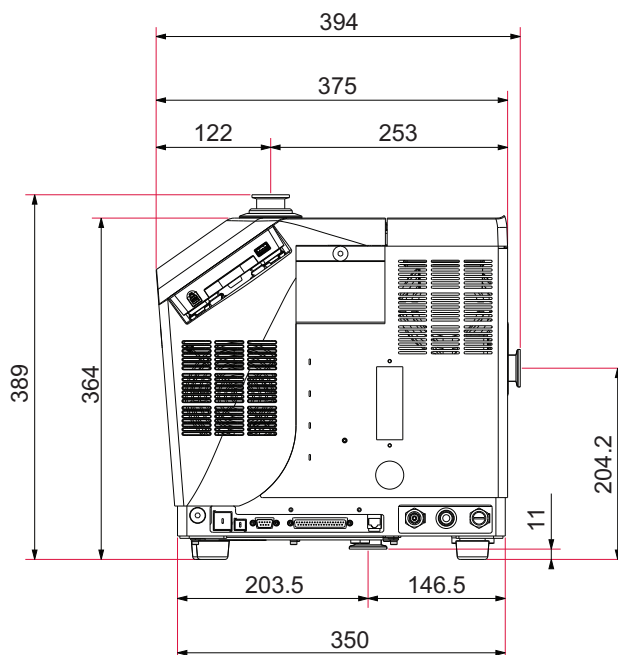
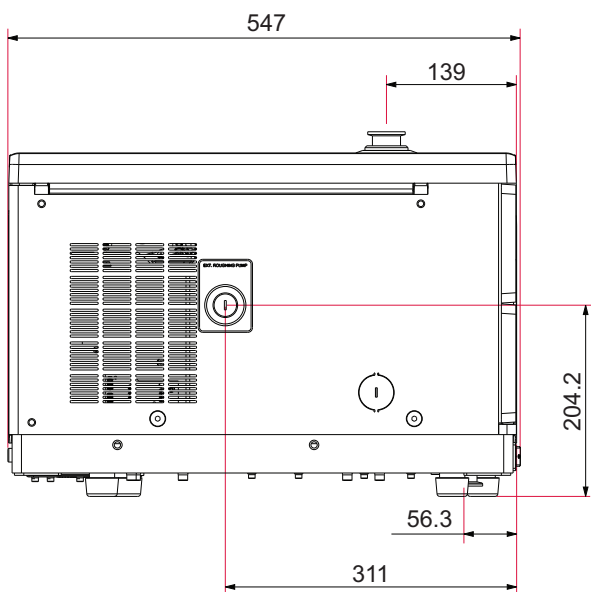

## 12 Appendix

### 12.1 Tree diagram of the Settings menu

Next tables indicate the default settings for the leak detector.

When the leak detector is switched off, values and parameters are saved for the next start-up.

Access: Settings Screen + Menu [Measurement]			Choice - Setting limit	
Tracer Gas			Helium 4 <sup>1)</sup> Mass 3 Hydrogen	
Set points	Pollution	Status	Enabled Disabled <sup>1)</sup>	
		Setting (if enabled)	$1 \cdot 10^{-19} - 1 \cdot 10^{+19}$ <b>1 · 10<sup>-05</sup> <sup>1)</sup></b>	
	Hard Vacuum Set Points	Reject point	$1 \cdot 10^{-13} - 1 \cdot 10^{-06}$ <b>1 · 10<sup>-08</sup> <sup>1)</sup></b>	
		Warning point	Status	Enabled <sup>1)</sup> Disabled
			Setting (if enabled)	0–100% <b>20% <sup>1)</sup></b>
	Sniffer set points	Reject point	$1 \cdot 10^{-12} - 1 \cdot 10^{+06}$ <b>1 · 10<sup>-04</sup> <sup>1)</sup></b>	
		Probe Clogged	$1 \cdot 10^{-19} - 1 \cdot 10^{+19}$ <b>1 · 10<sup>-06</sup> <sup>1)</sup></b>	
		Warning point	Status	Enabled <sup>1)</sup> Disabled
			Setting (if enabled)	0–100% <b>20% <sup>1)</sup></b>
	Other set points (If 37-pin I/O)	Set point #2	$1 \cdot 10^{-12} - 1 \cdot 10^{+06}$ <b>1 · 10<sup>-07</sup> <sup>1)</sup></b>	
		Set point #3	$1 \cdot 10^{-12} - 1 \cdot 10^{+06}$ <b>1 · 10<sup>-07</sup> <sup>1)</sup></b>	
		Set point #4	$1 \cdot 10^{-12} - 1 \cdot 10^{+06}$ <b>1 · 10<sup>-07</sup> <sup>1)</sup></b>	
		Set point #5	$1 \cdot 10^{-12} - 1 \cdot 10^{+06}$ <b>1 · 10<sup>-07</sup> <sup>1)</sup></b>	
	Other pressure set points (If 37-pin I/O)	Pressure set point #1	$1 \cdot 10^{-19} - 1 \cdot 10^{+19}$ <b>2 · 10<sup>-01</sup> <sup>1)</sup></b>	
Pressure set point #2		$1 \cdot 10^{-19} - 1 \cdot 10^{+19}$ <b>1 · 10<sup>+00</sup> <sup>1)</sup></b>		
Correction factor	Status	Enabled Disabled <sup>1)</sup>		
	Setting (if enabled)	$1 \cdot 10^{-19} - 1 \cdot 10^{+19}$ <b>1 · 10<sup>+00</sup> <sup>1)</sup></b>		

1) Default setting

2) General information: read only

3) No default setting: setting performed by the user at the 1<sup>st</sup> detector start-up

4) Information indicated on the calibrated leak used for calibration or on its calibration certificate.

Access: Settings Screen + Menu [Measurement]		Choice - Setting limit
Calibrated leak settings	Tracer Gas	Helium 4 <sup>1)</sup> Mass 3 Hydrogen
	Type	Internal <sup>1)</sup> External
	Unit	mbar · l/s Pa · m <sup>3</sup> /s Torr · l/s mTorr · l/s atm · cc/s sccm sccs ppm <sup>3)</sup> - <sup>3)</sup>
	Leak value	1 · 10 <sup>-18</sup> – 1 · 10 <sup>+18</sup> - <sup>4)</sup>
	Loss per year (%)	0 – 99 <b>6</b> <sup>1) 4)</sup>
	Reference temperature (°C)	0 – 99 <b>23</b> <sup>1) 4)</sup>
	Temperature coefficient (%/°C)	0.0 – 9.9 <b>3</b> <sup>1) 4)</sup>
	Date	Format: mm/yyyy - <sup>4)</sup>
Temperature	Type	Internal <sup>1)</sup> External
	Internal Temperature (°C) (if internal 'Type')	- - <sup>2)</sup>
	External Temperature (°C) (if external 'Type')	0 – 99 <b>23</b> <sup>1)</sup>

- 1) Default setting
- 2) General information: read only
- 3) No default setting: setting performed by the user at the 1<sup>st</sup> detector start-up
- 4) Information indicated on the calibrated leak used for calibration or on its calibration certificate.

**Tbl. 3: Default settings: 'Measurement' menu**

Access: Settings Screen + Menu [Test]	Choice - Setting limit
Method	Hard Vacuum <sup>1)</sup> Sniffer
Mode (if hard vacuum 'Method')	Gross Leak <b>Normal</b> <sup>1)</sup>
Probe type (if sniffer 'Method')	<b>Standard</b> <sup>1)</sup> Smart

- 1) Default setting
- 2) General information: read only



Access: Settings Screen + Menu [Test]			Choice - Setting limit
Cycle end	Cycle end		<b>Operator</b> <sup>1)</sup> Automatic
	Roughing timer (if automatic 'Cycle end')	Status	<b>Enabled</b> <sup>1)</sup> Disabled
		Setting	0 – 1 h <b>10 s</b> <sup>1)</sup>
Test timer (if automatic 'Cycle end')		0 – 1 h <b>10 s</b> <sup>1)</sup>	
Inlet vent	Inlet vent		<b>Operator</b> <sup>1)</sup> Automatic
	Delay (if automatic 'Inlet vent')		0 – 2 s <b>0 s</b> <sup>1)</sup>
	Vent timer (if automatic 'Inlet vent')	Status	Enabled <b>Disabled</b> <sup>1)</sup>
		Setting	00'00" – 59'59" <b>00'09"</b> <sup>1)</sup>
Memo Function	Active		Yes <b>No</b> <sup>1)</sup>
	Display time	Status	Enabled <b>Disabled</b> <sup>1)</sup>
		Setting	00'00" – 59'59" <b>00'10"</b> <sup>1)</sup>
Zero activation	Activation	Setting	None <b>Operator</b> <sup>1)</sup> Automatic
		Zero exit (if operator 'Activation')	
	Trigger (if automatic 'Activation')	Status	<b>Timer</b> <sup>1)</sup> Set point
		Setting (if timer)	00'00" – 59'59" <b>00'10"</b> <sup>1)</sup>
		Setting (if set point)	$1 \cdot 10^{-19}$ – $1 \cdot 10^{+19}$ <b><math>5 \cdot 10^{-07}</math></b> <sup>1)</sup>
	Regeneration	Function launching	
Massive Mode	Active		No <b>Yes</b> <sup>1)</sup>
	Sensitivity		<b>High</b> <sup>1)</sup> Low
Calibration check	Check		<b>Operator</b> <sup>1)</sup> Automatic
	Frequency (if automatic 'Check')	Every cycle	0 – 9999 <b>50</b> <sup>1)</sup>
		Every hour	00'00" – 59'59" <b>00'10"</b> <sup>1)</sup>
Calibration	Status		<b>Start-up</b> <sup>1)</sup> Operator Check at start

1) Default setting

2) General information: read only

Access: Settings Screen + Menu [Test]		Choice - Setting limit	
Dynamic calibration (Integrable model)	Active	Enabled <b>Disabled</b> <sup>1)</sup>	
	Value (if 'Active' is enabled)	$1 \cdot 10^{-19} - 1 \cdot 10^{+19}$ <b><math>1 \cdot 10^{-07}</math></b> <sup>1)</sup>	
	Coefficient	<b>1</b> <sup>1)</sup> - 2)	
Purge valve	Wet model	<b>Closed</b> <sup>1)</sup>	
	Dry Model	<b>Automatic</b> <sup>1)</sup> Closed Open	
	Integrable model	Closed <b>Open</b> <sup>1)</sup>	
Start-up timer	Value	00'00" – 59'59" <b>00'10"</b> <sup>1)</sup>	
Crossover pressures	Gross Leak	Wet and Dry models	$2,5 \cdot 10^{+1} - 1 \cdot 10^{+1}$ <b><math>2,5 \cdot 10^{+01}</math></b> <sup>1)</sup>
		Integrable model	$2,5 \cdot 10^{+1} - 5 \cdot 10^{-1}$ <b><math>5 \cdot 10^{+00}</math></b> <sup>1)</sup>
	Normal	Wet and Dry models	$5 \cdot 10^{-1} - 1 \cdot 10^{-1}$ <b><math>5 \cdot 10^{-01}</math></b> <sup>1)</sup>
		Integrable model	$5 \cdot 10^{-1} - 5 \cdot 10^{-2}$ <b><math>5 \cdot 10^{-01}</math></b> <sup>1)</sup>

1) Default setting

2) General information: read only

Tbl. 4: Default settings: 'Test' menu

Access: Settings Screen + Menu [Configuration]	Choice - Setting limit
Unit	mbar · l/s Pa · m <sup>3</sup> /s Torr · l/s atm · cc/s ppm sccm sccs mtorr · l/s - 3)
Date	Format: mm/dd/yyyy - 3)
Time	Format: hh:mm:ss - 3)

1) Default setting

3) No default setting: setting performed by the user at the 1<sup>st</sup> detector start-up

Access: Settings Screen + Menu [Configuration]			Choice - Setting limit
Language			English French German Italian Chinese Japanese Korean Spanish Russian Portuguese - 3)
Sound volume	Detector	Status	<b>Enabled</b> <sup>1)</sup> Disabled
		Setting	1 – 9 <b>3</b> <sup>1)</sup>
	Voice	Status	<b>Enabled</b> <sup>1)</sup> Disabled
		Setting	1 – 9 <b>4</b> <sup>1)</sup>
	Detector min. sound	Status	<b>Enabled</b> <sup>1)</sup> Disabled
		Setting	1 – 9 <b>0</b> <sup>1)</sup>

1) Default setting

3) No default setting: setting performed by the user at the 1<sup>st</sup> detector start-up

Access: Settings Screen + Menu [Configuration]		Choice - Setting limit
Function keys	Timer	Enabled <b>Disabled</b> <sup>1)</sup>
	Audio	<b>Enabled</b> <sup>1)</sup> Disabled
	Cor.	Enabled <b>Disabled</b> <sup>1)</sup>
	Mute	<b>Enabled</b> <sup>1)</sup> Disabled
	Reject point	<b>Enabled</b> <sup>1)</sup> Disabled
	Infor.	<b>Enabled</b> <sup>1)</sup> Disabled
	Tracer gas	Enabled <b>Disabled</b> <sup>1)</sup>
	Vent	<b>Enabled</b> <sup>1)</sup> Disabled
	Method	<b>Enabled</b> <sup>1)</sup> Disabled
	Mode	Enabled <b>Disabled</b> <sup>1)</sup>
	Memo	Enabled <b>Disabled</b> <sup>1)</sup>
	Paging	Enabled <b>Disabled</b> <sup>1)</sup>
	Regen	Enabled <b>Disabled</b> <sup>1)</sup>
	Cal type	<b>Enabled</b> <sup>1)</sup> Disabled
	Screen Shot	Enabled <b>Disabled</b> <sup>1)</sup>
Switch Set point	Enabled <b>Disabled</b> <sup>1)</sup>	

1) Default setting

3) No default setting: setting performed by the user at the 1<sup>st</sup> detector start-up

Access: Settings Screen + Menu [Configuration]		Choice - Setting limit	
Screen settings	Brightness	0 – 20 <b>15</b> <sup>1)</sup>	
	Paging Function	Enabled <b>Disabled</b> <sup>1)</sup>	
	Leak rate bar-graph	Zoom on set point	Enabled <b>Disabled</b> <sup>1)</sup>
		High decade	-12– +6 <b>-2</b> <sup>1)</sup>
		Low decade	-13 – +5 <b>-12</b> <sup>1)</sup>
		Lower display limit	$1 \cdot 10^{-13} - 1 \cdot 10^{+06}$ <b>1 \cdot 10^{-13}</b> <sup>1)</sup>
		Show 2 <sup>nd</sup> digit	Enabled <b>Disabled</b> <sup>1)</sup>
	Application windows	Std-by Value	<b>Hide</b> <sup>1)</sup> Show
		Show inlet pressure	Hide <b>Show</b> <sup>1)</sup>
		Show second pressure	<b>None</b> <sup>1)</sup> Cell. Ext.
		Show synoptic	Hide <b>Show</b> <sup>1)</sup>
	Reset screen parameters	Function launching	-

1) Default setting

3) No default setting: setting performed by the user at the 1<sup>st</sup> detector start-up

Access: Settings Screen + Menu [Configuration]				Choice - Setting limit
Access/Password	User level			Restricted access Medium access <b>Full access <sup>1)</sup></b>
	Password			- <b>5555 <sup>1)</sup></b>
	Customized access	if access restricted 'User level'	Graph screen	Access permitted <b>Access denied <sup>1)</sup></b>
			Measurement menu	Access permitted <b>Access denied <sup>1)</sup></b>
			Test menu	Access permitted <b>Access denied <sup>1)</sup></b>
			Configuration menu	Access permitted <b>Access denied <sup>1)</sup></b>
			Maintenance menu	Access permitted <b>Access denied <sup>1)</sup></b>
			File manager menu	Access permitted <b>Access denied <sup>1)</sup></b>
			Advanced menu	Access permitted <b>Access denied <sup>1)</sup></b>
		if medium access or full access 'User level'	Graph screen	<b>Access permitted <sup>1)</sup></b> Access denied
			Measurement menu	<b>Access permitted <sup>1)</sup></b> Access denied
			Test menu	<b>Access permitted <sup>1)</sup></b> Access denied
			Configuration menu	<b>Access permitted <sup>1)</sup></b> Access denied
			Maintenance menu	<b>Access permitted <sup>1)</sup></b> Access denied
File manager menu			<b>Access permitted <sup>1)</sup></b> Access denied	
Advanced menu			<b>Access permitted <sup>1)</sup></b> Access denied	

1) Default setting

3) No default setting: setting performed by the user at the 1<sup>st</sup> detector start-up

**Tbl. 5: Default settings: 'Configuration' menu**

Access: Settings Screen + Menu [Maintenance]		Choice - Setting limit
History	Events history	- <sup>2)</sup>
	Calibrations history	- <sup>2)</sup>

1) Default setting

2) General information: read only

5) No default setting

Access: Settings Screen + Menu [Maintenance]			Choice - Setting limit		
Information	Detector	Timer	_ 2)		
		Date and time	_ 2)		
		Software release .LC4	_ 2)		
		Software release .CPX	_ 2)		
		Software release .CEN	_ 2)		
		Inlet pressure	_ 2)		
		Reject point	_ 2)		
		Warning point	_ 2)		
		Correction	_ 2)		
		Tracer gas	_ 2)		
		Filament	_ 2)		
		Cell status	_ 2)		
		Method	_ 2)		
		Mode (if 'hard vacuum' method)	_ 2)		
		Probe type (if 'sniffer' method)	_ 2)		
		Calibration	_ 2)		
		Last calibration	_ 2)		
		Next maintenance	_ 2)		
		Analyzer cell	Filament selected	Filament	_ 2)
				Cell status	_ 2)
	Triode pressure			_ 2)	
	Electronic zero			_ 2)	
	Target value			_ 2)	
	Acceleration voltage			_ 2)	
	Emission measurement			_ 2)	
	Sensitivity coefficient			_ 2)	
	Cell temperature			_ 2)	
	Timer filament 1			Value	<b>20 h<sup>1)</sup></b> _ 2)
				Reset timer	Function launching -
	Timer filament 2		Value	<b>0 h<sup>1)</sup></b> _ 2)	
			Reset timer	Function launching -	
	Backing pump		Timer backing pump	Wet model	<b>20/8 600 h<sup>1)</sup></b> _ 2)
				Dry model	<b>20/17 200 h<sup>1)</sup></b> _ 2)
		Integrable model		<b>0/0 h<sup>1)</sup></b>	
		Status	_ 2)		
		Speed	_ 2)		
	Turbo pump	Timer turbo pump	<b>20/17 200 h<sup>1)</sup></b> _ 2)		
		Status	_ 2)		
		Speed	_ 2)		

1) Default setting

2) General information: read only

5) No default setting

Access: Settings Screen + Menu [Maintenance]			Choice - Setting limit
Last maintenance operations	Maintenance work 1	Date	_ 5)
		Inspector name	_ 5)
		Total hours	_ 5)
		Comments	_ 5)
	Maintenance work 2	Date	_ 5)
		Inspector name	_ 5)
		Total hours	_ 5)
		Comments	_ 5)
	Maintenance work 3	Date	_ 5)
		Inspector name	_ 5)
		Total hours	_ 5)
		Comments	_ 5)
Timers before next maintenance	Valves		<b>500 000 cycles</b> <sup>1)</sup> _ 2)
	Backing pump	Wet model	<b>20/8 600 h</b> <sup>1)</sup> _ 2)
		Dry model	<b>20/17 200 h</b> <sup>1)</sup> _ 2)
		Integrable model	<b>0/0 h</b> <sup>1)</sup>
	Turbo pump		<b>20/17 200 h</b> <sup>1)</sup> _ 2)
Maintenance turbo pump and cell	Filament		<b>Filament 1</b> <sup>1)</sup> Filament 2
	Stop and vent	Function launching	-
		Restart leak detector	Function launching
Burn-in	Inlet vent	'Inlet vent' function access	-
	Start without calib.	Function launching	-
	Start with calibration	Function launching	-
	Stop	Function stop	-
Internal Pirani Calibration	Pressure		_ 2)
	Inlet pressure		_ 2)
	HV valid	Function launching	-
	Hard Vacuum		_ 2)
	Atm valid	Function launching	-
	Atmospheric		_ 2)
	Start/Stop	Function launching	-
	Inlet vent	Function launching	-

1) Default setting  
 2) General information: read only  
 5) No default setting



Access: Settings Screen + Menu [Maintenance]			Choice - Setting limit
External gauge	Gauge		<b>None</b> <sup>1)</sup> TPR/PCR Linear
	External Pressure (mbar)		- <sup>2)</sup>
	P. Inlet Source		<b>Internal</b> <sup>1)</sup> External
	Full scale (mbar) (if linear)		0,1 – 5000 - <sup>5)</sup>
Save LD Parameters	Save LD Parameters	Function launching	-
	Load LD Parameters	Function launching	-

1) Default setting

2) General information: read only

5) No default setting

**Tbl. 6: Default settings: 'Maintenance' menu**

Access: Settings Screen + Menu [File Manager]	Choice - Setting limit
Internal memory	-
USB stick	-

**Tbl. 7: Default settings: 'File Manager' menu.**

Access: Settings Screen + Menu [Advanced]		Choice - Setting limit	
Input/Output	Serial link 1	Type	<b>Serial</b> <sup>1)</sup>
		Mode	Basic Table <b>Advanced</b> <sup>1)</sup> Export Data RC 500 WL RC 500 HLT 5xx HLT 2xx Ext. module
		Period (if table 'Mode')	0 s – 24 h <b>1 s</b> <sup>1)</sup>
		Handshake	Yes <b>No</b> <sup>1)</sup>
		Power pin 9	5 V <sup>1)</sup>
	Serial link 2	Type	<b>USB</b> <sup>1)</sup> Anybus Not used <sup>3)</sup>
		Mode	Basic Table <b>Advanced</b> <sup>1)</sup> Export Data RC 500 WL RC 500 HLT 5xx HLT 2xx Ext. module
		Period (if table 'Mode')	0 s – 24 h <b>1 s</b> <sup>1)</sup>
		Handshake	Yes <b>No</b> <sup>1)</sup>
		Module	- <sup>2)</sup>
		Name	- <sup>2)</sup>
	I/O Connector	Quick view <sup>6)</sup>	- <sup>6) 7)</sup>
		Analog Output	- <sup>7)</sup>
		Digital input <sup>6)</sup>	- <sup>6) 7)</sup>
Transistor output <sup>6)</sup>		- <sup>6) 7)</sup>	
Relay output <sup>6)</sup>		- <sup>6) 7)</sup>	
Default configuration <sup>6)</sup>		- <sup>6) 7)</sup>	
Other configurations <sup>6)</sup>		- <sup>6) 7)</sup>	
Service	Access to the Service menu is password protected. Reserved for our Service Centers.	-	

1) Default setting

2) General information: read only

6) 37-pin I/O only

7) See the I/O communication interface operating instructions

**Tbl. 8: Default settings: 'Advanced' menu**

Access: Press the [SWITCH SETPOINT] function key	Choice - Setting limit
Set point A	$1 \cdot 10^{-13} - 1 \cdot 10^{+06}$ <b>1 · 10<sup>-06</sup> 1)</b>
Set point B	$1 \cdot 10^{-13} - 1 \cdot 10^{+06}$ <b>1 · 10<sup>-08</sup> 1)</b>
1) Default setting	

Tbl. 9: Initial settings: Function key - [SWITCH SETPOINT]

Access: Press the graph	Choice - Setting limit		
Graph parameters	Display time	12 s – 1 h <b>30 s 1)</b>	
	Auto scale	Status	Enabled <b>Disabled 1)</b>
		Setting (if 'Auto scale' is enabled)	<b>2 decades 1)</b> 4 decades
	Decade (if 'Auto scale' is enabled)	High decade	-11 – +6 <b>-4 1)</b>
		Low decade	-12 – +5 <b>-10 1)</b>
	Show inlet pressure	Enabled <b>Disabled 1)</b>	
	Pressure decade (if 'Show inlet pressure' is enabled)	High decade	-2 – +3 <b>+3 1)</b>
		Low decade	-3 – +2 <b>-3 1)</b>
Enable record	Enabled <b>Disabled 1)</b>		
Sampling rate (if 'Enable record' is enabled)	100 ms – 30 s <b>500 ms 1)</b>		
Clear recording (if 'Enable record' is enabled)	Function launching	-	
View record (if 'Enable record' is enabled)	Function launching	-	
1) Default setting			

Tbl. 10: Initial settings: Graph screen - Graph parameters

# Certificate



Certificate no.

CU 72182417 01

**License Holder:**  
Pfeiffer Vacuum SAS  
98 Avenue de Brogny  
74009 Annecy  
France

**Manufacturing Plant:**  
Pfeiffer Vacuum SAS  
98 Avenue de Brogny  
74009 Annecy  
France

**Test report no.:** USA- 31884401 001

**Client Reference:** Julien Coulomb

**Tested to:** UL 61010-1:2012 R4.16  
CAN/CSA-C22.2 NO. 61010-1-12 + GI1 + GI2 (R2017)

**Certified Product:** Leak Detector

**License Fee - Units**

Model

Designation: ASM340 WET (1)  
ASM340 DRY (2)  
ASM340I (3)  
Vista module (4)

7

Ratings : (1) AC 100-110 V or 200-240 V 50/60 Hz 850 W  
(2) AC 100-240 V 50/60Hz 600W  
(3) AC 100-240 V 50/60Hz 350W  
(4) DC 24 V 300W

Appendix: 1, 1-19

7

**Licensed Test mark:**

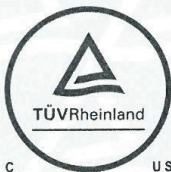

**Date of Issue**  
(day/mo/yr)  
06/02/2019

TUV Rheinland of North America, Inc., 12 Commerce Road, Newtown, CT 06470, Tel (203) 426-0888 Fax (203) 426-4009

# Declaration of Conformity

Declaration for product(s) of the type:

**Leak detector**  
**ASM 340 Wet**  
**ASM 340 Dry**  
**ASM 340 Integrable**

We hereby declare that the listed product satisfies all relevant provisions of the following **European Directives**.

**Machinery 2006/42/EC (Annex II, no. 1 A)**  
**Basel 2011/65/EU**  
**Electromagnetic compatibility 2014/30/EU**  
**Restriction of the use of certain hazardous substances 2011/65/EU**  
**Waste of Electrical and Electronic Equipment 2012/19/EU**

**Harmonized standards and national standards and specifications which have been applied:**

French standard NF EN 61010-1: 2011  
French standard NF EN 60204-1: 2006  
French standard NF EN 61326-1: 2013  
French standard NF EN 50581: 2013

The person responsible for compiling the technical file is Mr. Arnaud Favre, Pfeiffer Vacuum SAS, 98, avenue de Brogny B.P. 2069, 74009 Annecy cedex.

---

Signature:



Pfeiffer Vacuum SAS  
98, avenue de Brogny  
74009 Annecy cedex  
France  
B.P. 2069

---

Arnaud Favre  
Product Group Director Instrumentation and Systems  
Pfeiffer Vacuum SAS

Annecy, 2021/11/18



# Declaration of incorporation of partly completed machinery

Declaration for product(s) of the type:

**Leak detector**  
**ASM 340 Integrable**

We hereby declare that the listed product satisfies all relevant provisions of the following **European Directives**.

**Machinery 2006/42/EC (Annex II, no. 1 A)**  
**Basse tension 2014/35/CE**  
**Electromagnetic compatibility 2014/30/EU**  
**Restriction of the use of certain hazardous substances 2011/65/EU**  
**Waste of Electrical and Electronic Equipment 2012/19/EU**

**Harmonized standards and national standards and specifications which have been applied:**

NF EN 61010-1 : 2011  
NF EN 60204-1 : 2006  
NF EN-61326-1 : 2013  
NF EN 50581 : 2013

This product should not be put into service before the machine that they will ultimately be incorporated into has been deemed compliant with Machinery Directive 2006/42/EC.

The undersigned also undertake to pass on pertinent information on the partly completed machinery, in response to any reasoned request properly formulated by a national authority.

The person responsible for compiling the technical file is Mr. Arnaud Favre, Pfeiffer Vacuum SAS, 98, avenue de Brogny B.P. 2069, 74009 Annecy cedex.

Signature:



Pfeiffer Vacuum SAS  
98, avenue de Brogny  
74009 Annecy cedex  
France  
B.P. 2069

Arnaud Favre  
Product Group Director Instrumentation and Systems  
Pfeiffer Vacuum SAS

Annecy, 2021/11/17





## VACUUM SOLUTIONS FROM A SINGLE SOURCE

Pfeiffer Vacuum stands for innovative and custom vacuum solutions worldwide, technological perfection, competent advice and reliable service.

## COMPLETE RANGE OF PRODUCTS

From a single component to complex systems:

We are the only supplier of vacuum technology that provides a complete product portfolio.

## COMPETENCE IN THEORY AND PRACTICE

Benefit from our know-how and our portfolio of training opportunities!

We support you with your plant layout and provide first-class on-site service worldwide.

Ed. 02 - Date 2022/07 - P/N:128863OEN



Are you looking for a  
perfect vacuum solution?  
Please contact us

Pfeiffer Vacuum GmbH  
Headquarters • Germany  
T +49 6441 802-0  
info@pfeiffer-vacuum.de

[www.pfeiffer-vacuum.com](http://www.pfeiffer-vacuum.com)