



Chemistry



Vacuum distillation



Vacuum furnaces

OktaLine® ATEX

Explosion-proof Roots pumps

OktaLine® ATEX

Explosion-proof Roots pumps



Your added value



Hermetically sealed
for maximum
operational safety



Explosion-proof due to
pressure surge resistance
to PN 16

ATEX approval for use in rough and fine vacuum

OktaLine Roots pumps are the right choice for processes in potentially explosive atmospheres or for evacuating explosive gases. Thanks to conformity to ATEX Directive 2014/34/EU¹⁾ and pressure surge resistance to PN16, they meet the highest requirements for explosion protection.

Hermetically sealed for maximum operational reliability

Thanks to their magnetic coupling with non-metallic separating can, OktaLine pumps are hermetically sealed and achieve lowest leakage rates of 10^{-6} Pa m³/s. Zone entrainment of explosive gases is thus excluded. The integrated temperature sensor protects against thermal overload. This monitors the gas temperature in the outlet area.

Large pumping speed range

The nominal pumping speed of the series ranges from 280 to 8,100 m³/h. Depending on the application, a choice can be made between equipment category 2G and 3G. All pumps are suitable for temperature class T3 – in some cases T4 is also possible. Since the pump has no effective ignition sources, installation is possible without flame arresters. This means that the full pumping speed of the pump is effectively available.

¹⁾ Directive 1999/92/EC applies to the operator.



Technically dry operation



Can be used individually
for ambient temperatures
from -20°C to +40°C



Higher performance
with a pumping speed
up to 8,100m³/h



Protection against thermal
overload thanks to integrated
temperature sensor



Easy installation and
maintenance

Technically dry operation

The gear and bearing housings are separated from the pump chamber by labyrinth seals. Contact-free rotation of the Roots ensures technically dry operation.

Flexible in application

Thanks to the variable differential pressure and flexible rotation speed, the pumps can be used universally. All pumps can be used in ambient temperatures from -20°C to +40°C.

Low operating costs and easy maintenance

Compared to pumps with shaft seals, the magnetic coupling used ensures up to 20% lower operating costs and significantly reduced maintenance costs. OktaLine pumps can also be operated without an external bypass, as ATEX protection is guaranteed even in the case of passive windmilling. The use of explosion-proof motors according to IEC standard allows quick and easy replacement on site.

Applications

- Chemical industry
- Pharmaceutical industry
- Automotive industry
- Heat treatment
- Vacuum drying
- Vacuum furnaces
- Biotechnology

OktaLine® ATEX

ATEX regulations



Certification for ATEX

The word ATEX is an acronym from French and stands for **ATmosphères EXplosibles**. Vacuum pumps for use in a potentially explosive atmosphere must be certified in accordance with 2014/34/EU. To do this, the measures shown in Figure 1 must be carried out.

The first step is the analysis of potential ignition sources. Depending on the category in the CE marking, the status regular operation (category 3), expected failure (category 2) and rare failure (category 1) are considered with regard to potential ignition sources. The next step is to prevent these ignition sources from becoming effective. The EN 1127-1 standard lists possible ignition sources that are examined as part of the ignition hazard assessment.

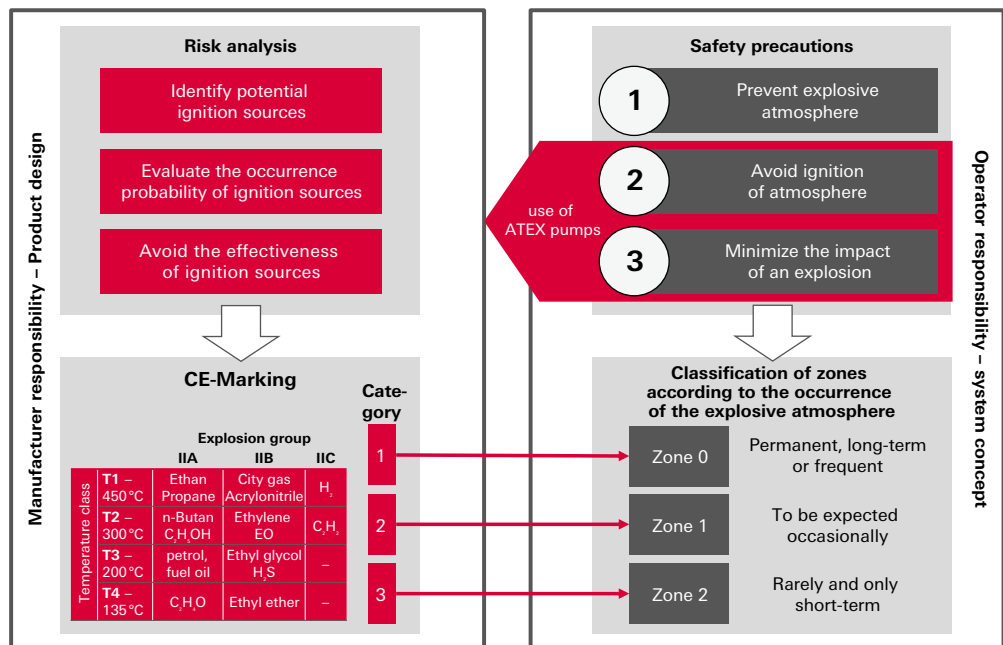

Figure 1: Responsibilities according to Directives 2014/34/EU and 1999/92/EG

According to Directive 1999/92/EC, the operator is first obliged to check whether the explosive atmosphere can be prevented. This is the case if a critical quantity of combustible material and sufficient oxidizing agents (usually oxygen) occur simultaneously. If this cannot be avoided, the second step is to prevent the atmosphere from igniting.

Operating principle of Roots pumps

Figure 2 shows the schematic structure of Roots pumps. Inside them, two Roots (4) rotate in opposite directions. They move the gas in the housing from the suction port (3) to the pressure port (11).

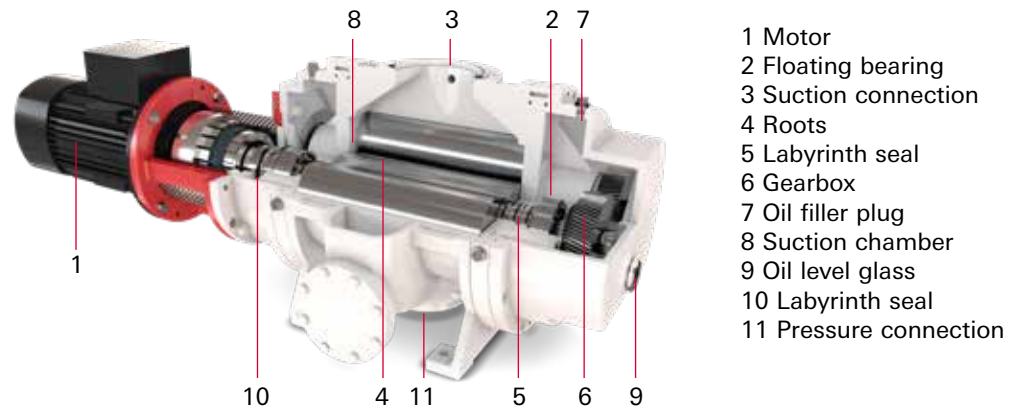

Figure 2: Schematic design of a Roots vacuum pump

(3) to the pressure port (11). A motor (1) drives the main lobe. The pair of gears (6) in the gear chamber synchronizes two rotors piston. Lubricants are used exclusively in the gear and bearing housings.

These are separated from the suction chamber (8) by a labyrinth seal (5). Narrow gaps between the piston and housing ensure contact-free running. This allows operation at high speed (1,500–4,500 rpm).

Heating of the pump

The pumped medium is neither compressed inside the Roots pumps nor does an check-valve at the discharge connection prevent backflow.

For this reason, there is a backflow of gas from the outlet into the pumping chamber as soon as the position of the Roots allows this. As a consequence, this backflow must also be conveyed against the outlet pressure. This effect leads to high energy consumption, especially at high differential pressures between inlet and outlet, which results in significant heating of the pump.

Limiting the differential pressure

For technical reasons, standard Roots pumps cannot operate against atmospheric pressure. With the aid of backing pumps, the pressure at the outlet is kept sufficiently low. In the smaller sizes, a built-in overflow valve prevents overheating by limiting the differential pressure. This overflow valve opens and closes an internal bypass connecting the suction and discharge sides of the housing. The limitation of the differential pressure can also be achieved by operating the pumps with a frequency converter. In this case, the speed of the pump is flexibly adapted to the operating conditions. Thanks to these measures, the Roots pumps can already be switched on at atmospheric pressure together with the backing pump. This enables faster evacuation; it also makes the pump much easier to use.

OktaLine® ATEX

Dimensional drawings

Okta 500 ATEX

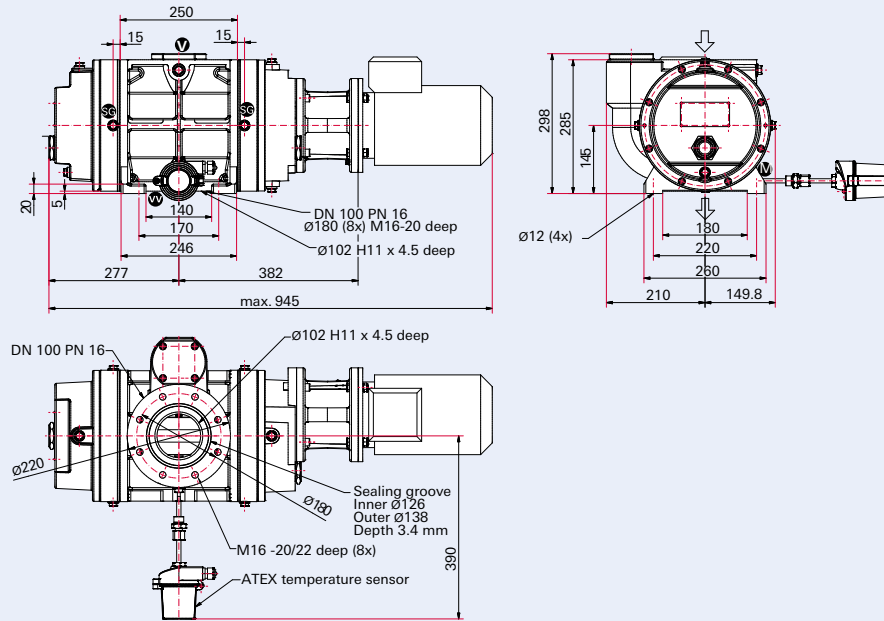

Okta 1000 ATEX

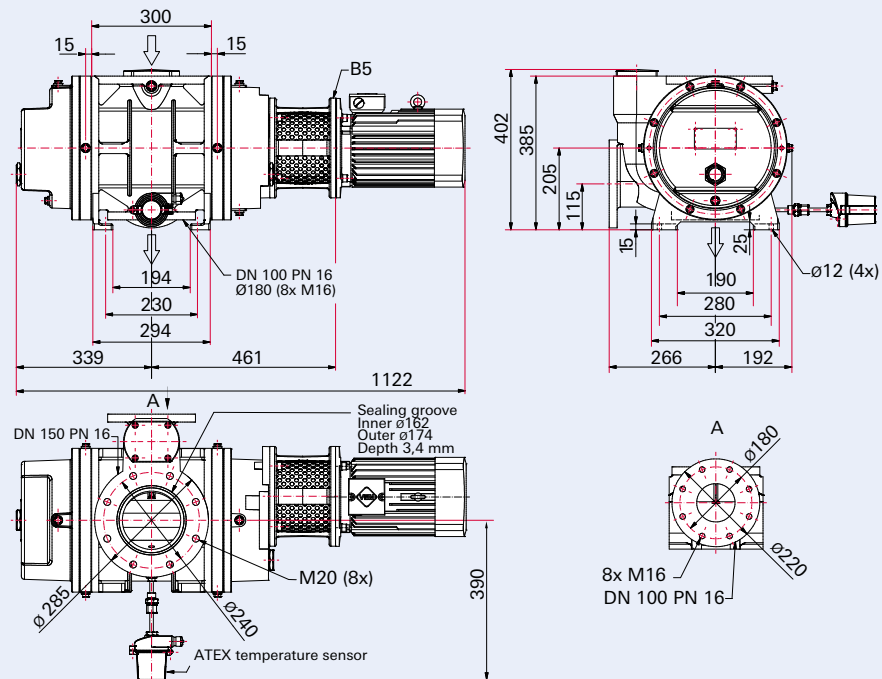

Dimensions in mm

Okta 2000 ATEX

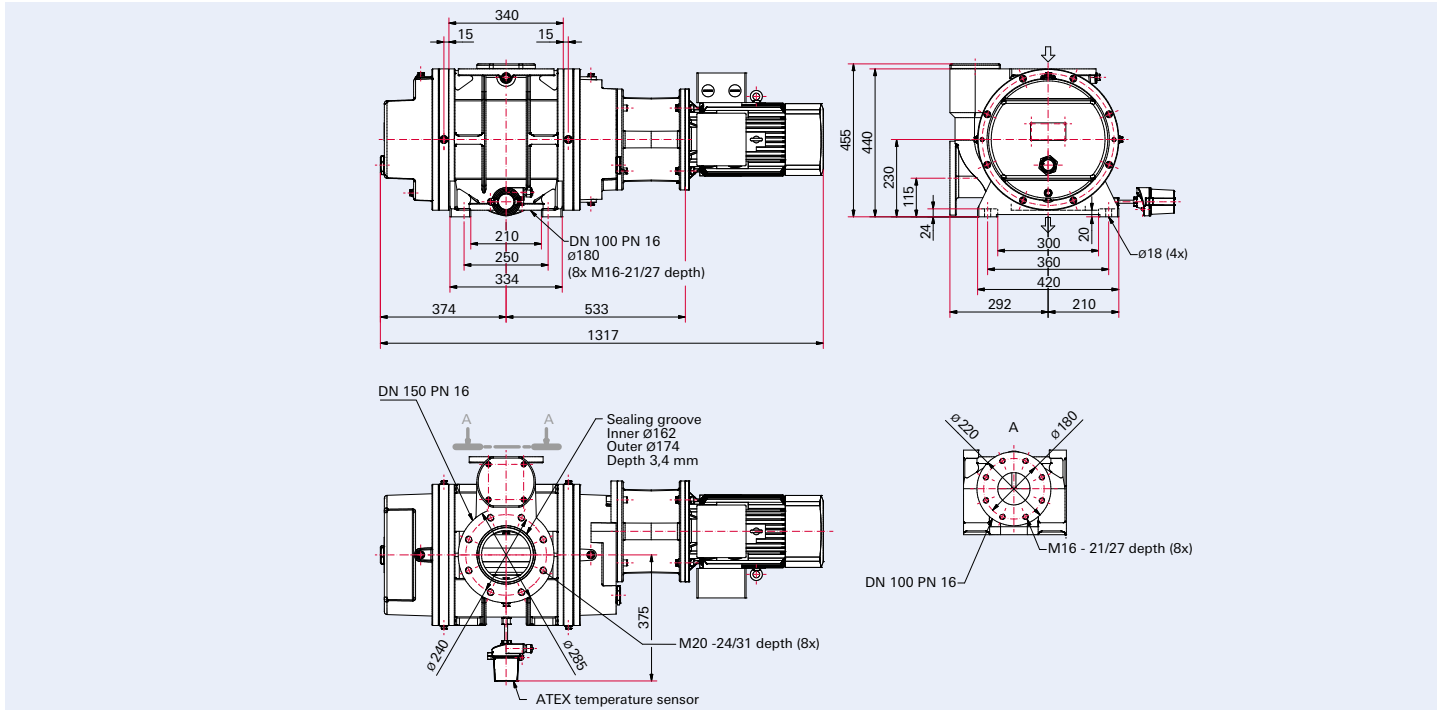

Okta 5400 / 8100 ATEX

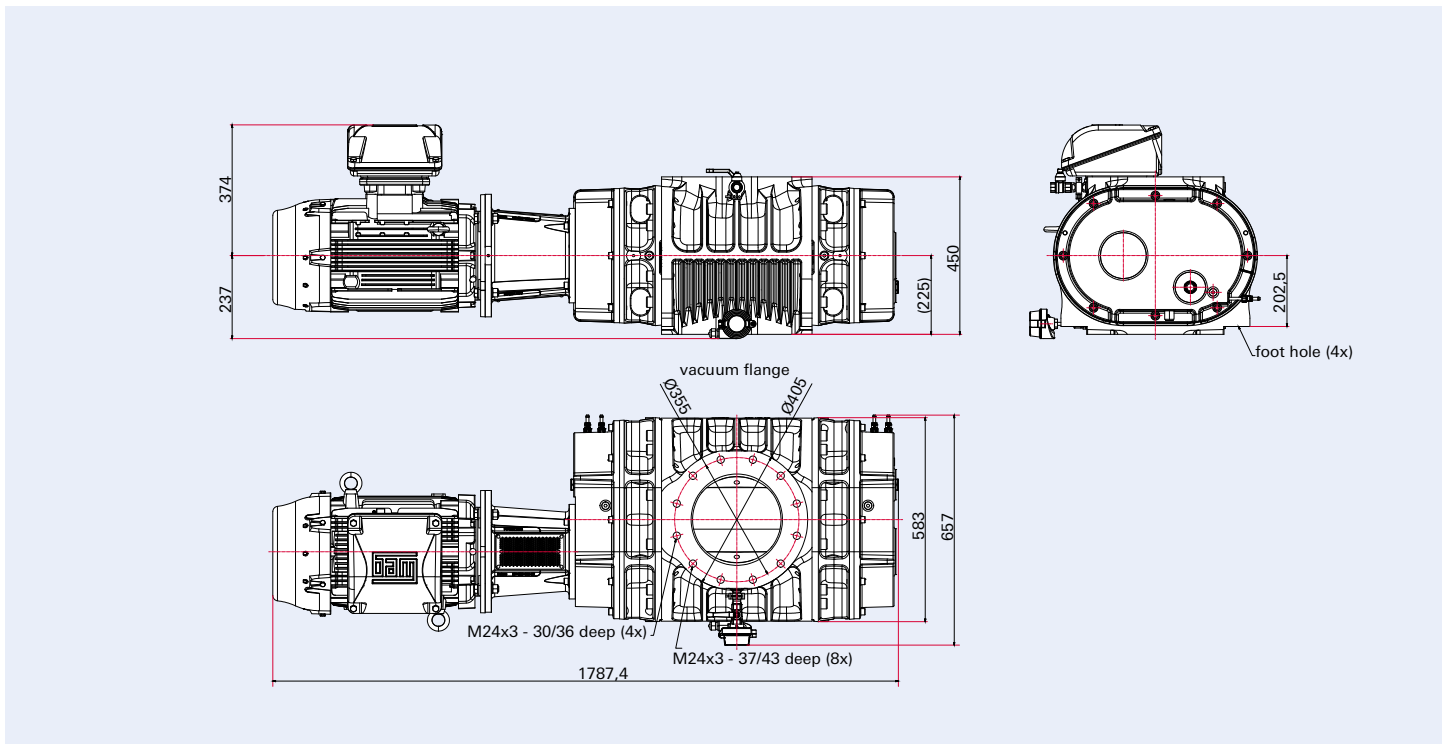

Dimensions in mm

OktaLine® ATEX

Pumping speed

Okta 500 ATEX

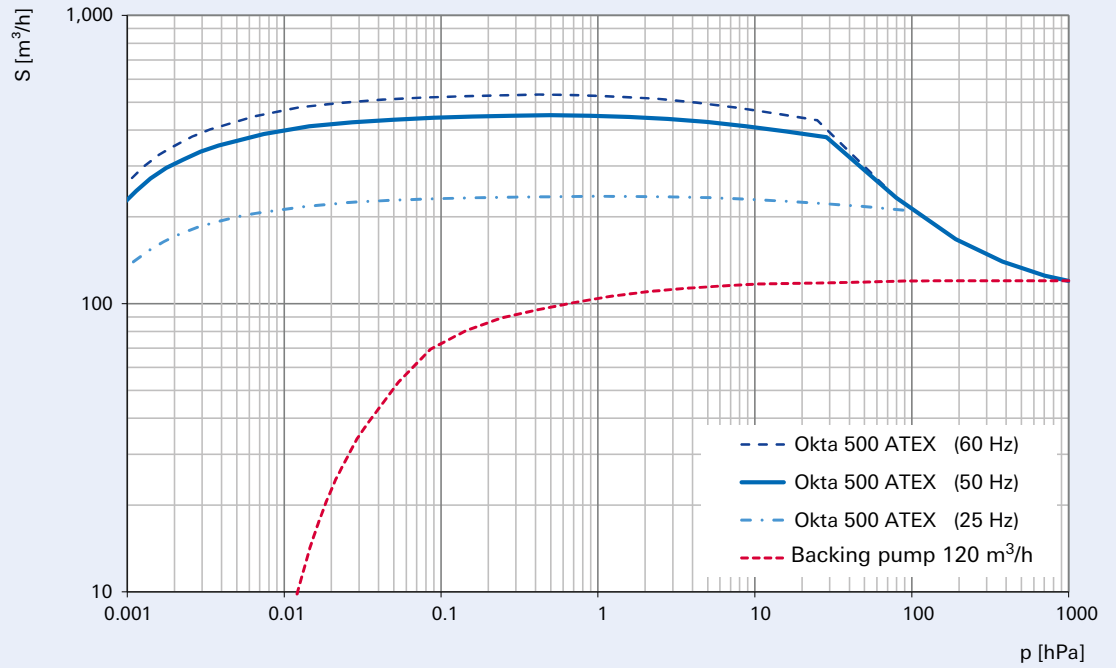

Okta 1000 ATEX

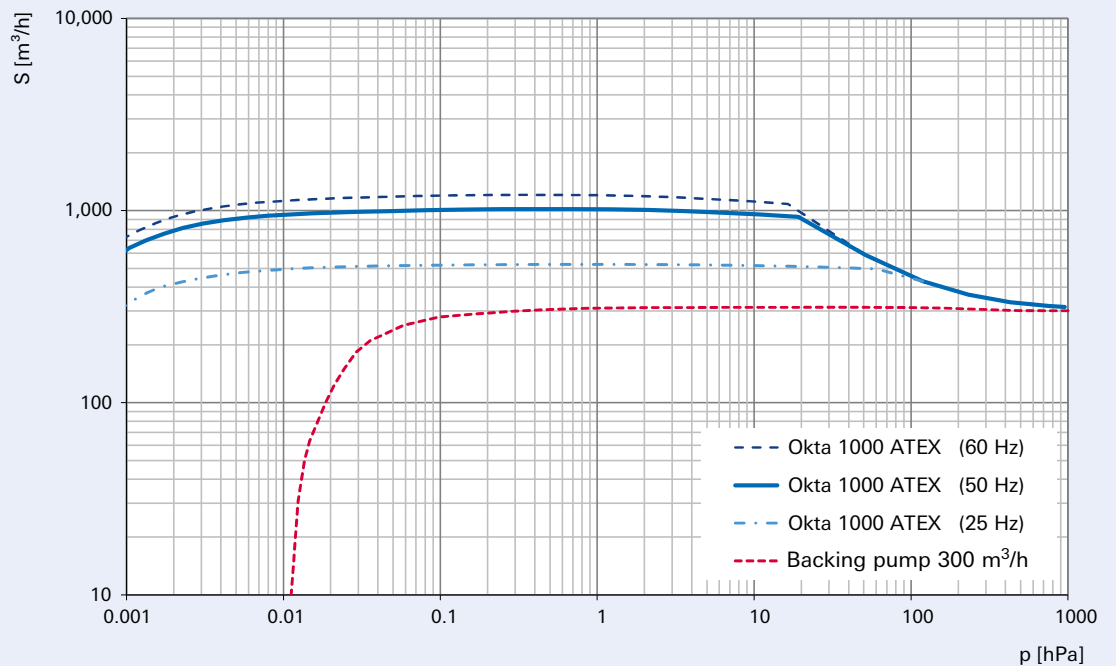

Okta 2000 ATEX

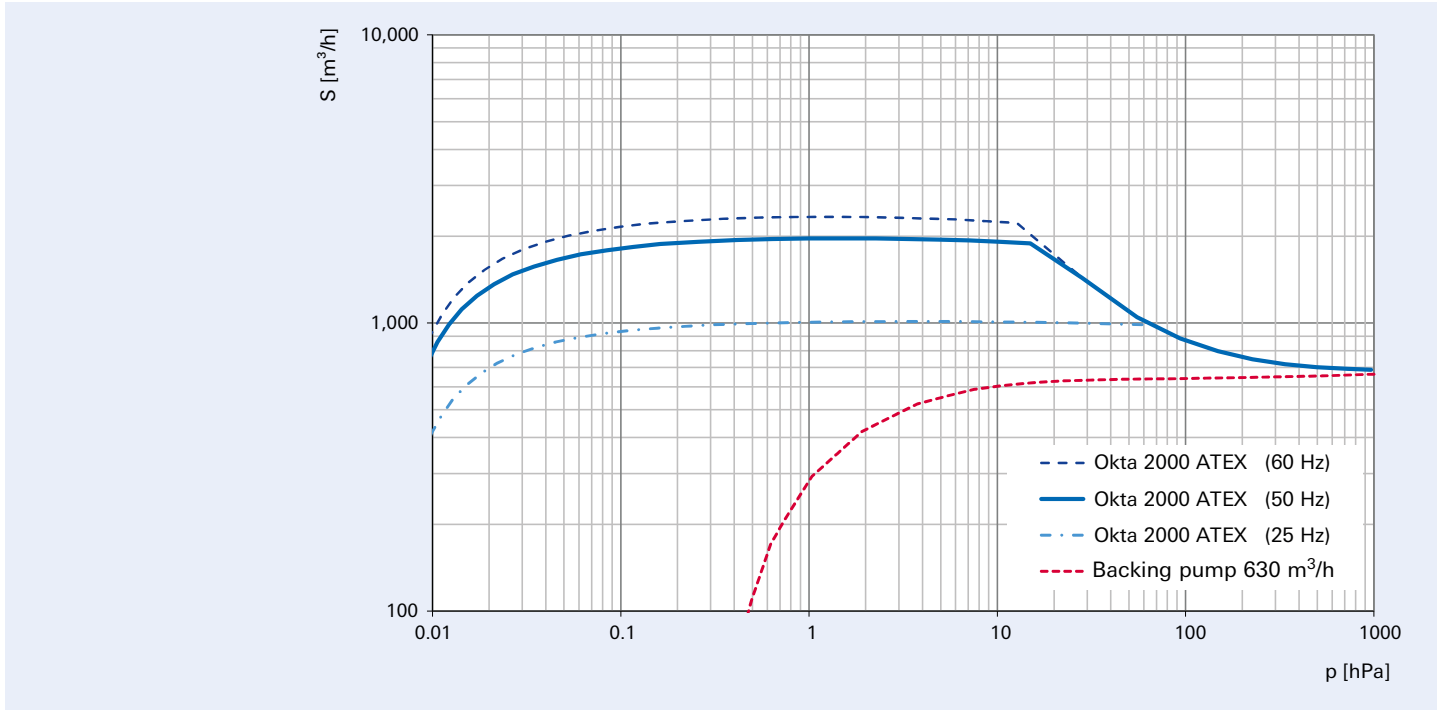

Okta 5400 / 8100 ATEX

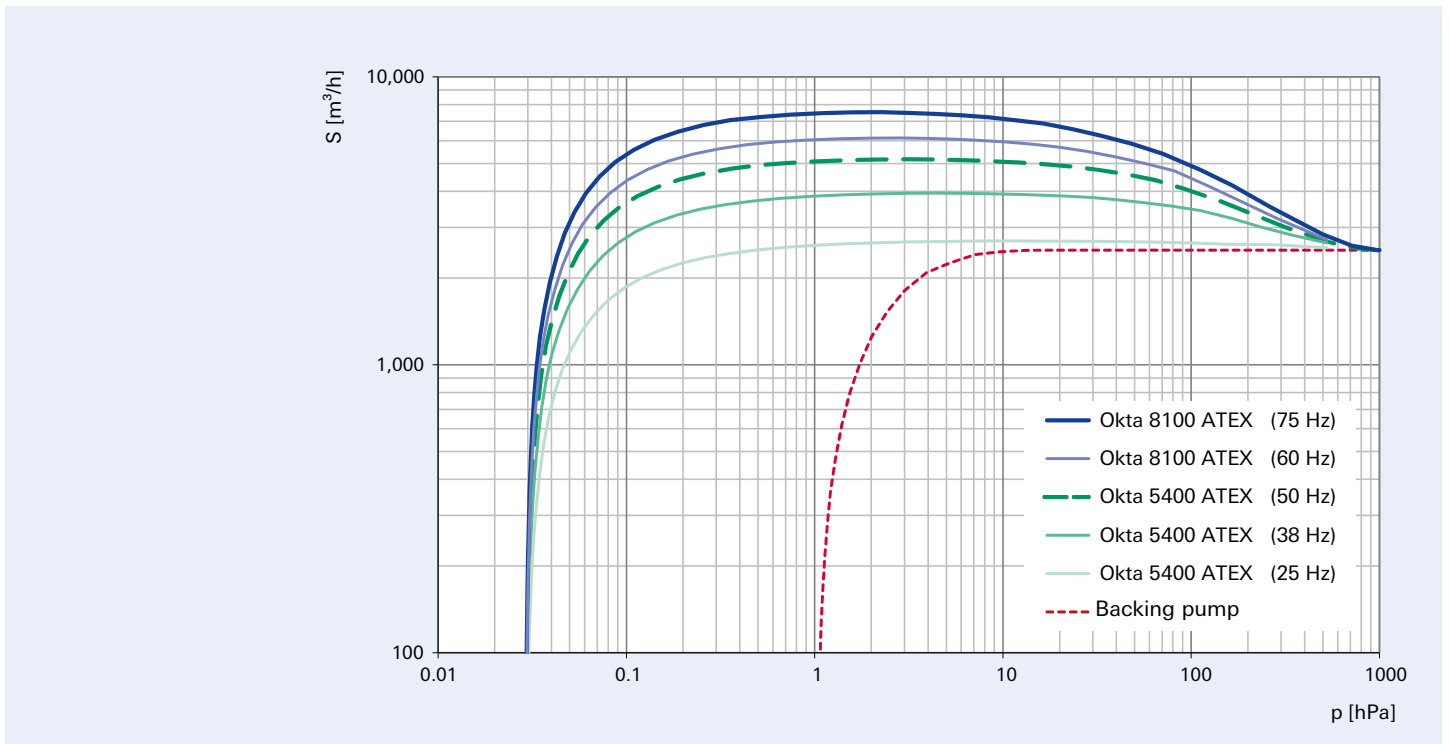

OktaLine® ATEX

Technical data

Technical data

| | Okta 500 ATEX | Okta 1000 ATEX | Okta 2000 ATEX |
|---|---|-----------------------------|-------------------------------|
| Version | ATEX with motor and magnetic coupling, blocked overflow valve | | |
| Equipment category | 2G ²⁾ or 3G ³⁾ | | |
| Nominal pumping speed | 560 m ³ /h | 1,180 m ³ /h | 2,155 m ³ /h |
| Pumping speed range | 280–670 m ³ /h | 590–1,420 m ³ /h | 1,080–2,585 m ³ /h |
| Pumping speed at 60 Hz | 670 m ³ /h | 1,420 m ³ /h | 2,585 m ³ /h |
| Rated speed | 3,000 min ⁻¹ | | |
| Speed min. | 1,500 min ⁻¹ | | |
| Max. speed | 3,600 min ⁻¹ | | |
| Connection flange (inlet) | DN 100 PN 16 | DN 150 PN 16 | DN 150 PN 16 |
| Connection flange (output) | DN 100 PN 16 | DN 100 PN 16 | DN 100 PN 16 |
| Weight: with motor | 154 kg | 255 kg | 390 kg |
| Leak rate | 1 · 10 ⁻⁶ Pa m ³ /s | | |
| Ambient temperature | 5–40 °C (-20–+40 °C) | | |
| Cooling type, standard | Air | | |
| Operating medium ¹⁾ | P3 | | |
| Operating medium quantity | 1.5 l. | 2,9 l | 5 l |
| Emission sound pressure level (EN ISO 2151) at intake pressure 10 hPa | 75 dB (A) | | |
| Emission sound pressure level (EN ISO 2151) at intake pressure 1 hPa | 70 dB (A) | 72 dB (A) | 72 dB (A) |
| Nominal power 50 Hz | 1.5 kW | 3.0 kW | 5.5 kW |
| Rated power 60 Hz | 1.8 kW | 3.5 kW | 6.3 kW |
| Mains connection: Voltage 50 Hz | 230/400 V | | |
| Mains connection: Voltage 60 Hz | 265/460 V | | |
| Motor protection | 3TF | | |
| Protection class | IP 55 | | |

Order numbers

| | Okta 500 ATEX | Okta 1000 ATEX | Okta 2000 ATEX |
|----------------|--------------------------|--------------------------|--------------------------|
| Okta ATEX (3G) | PP W33 300 ³⁾ | PP W43 300 ³⁾ | PP W63 300 ³⁾ |
| Okta ATEX (2G) | PP W33 400 ²⁾ | PP W43 400 ²⁾ | PP W63 400 ²⁾ |

¹⁾ Other equipment and motor voltages on request.

²⁾ Classification according to ATEX Directive 2014/34/EU: II 2/2G IIB T3 Gb +5 °C ≤ Ta ≤ +40°C

³⁾ Classification according to ATEX Directive 2014/34/EU: II 3/3G IIB T3 Gc +5 °C ≤ Ta ≤ +40°C

⁴⁾ Classification according to ATEX Directive 2014/34/EU: II 2/2G IIC T4...T2 Gb +5 °C ≤ Ta ≤ +40°C

| Okta 5400 ATEX | Okta 8100 ATEX |
|--|-------------------------|
| ATEX with motor and magnetic coupling without overflow valve | |
| 2G ⁴⁾ or 3G ⁴⁾ | |
| 5,400 m ³ /h | 8,100 m ³ /h |
| 2,700–8,100 m ³ /h | |
| 6,480 m ³ /h | |
| 3,000 min ⁻¹ | 4,500 min ⁻¹ |
| 1,500 min ⁻¹ | |
| 4,500 min ⁻¹ | |
| DN 250 PN16 | DN 250 PN16 |
| DN 250 PN16 | DN 250 PN16 |
| 790 kg | 810 kg |
| 1 · 10 ⁻⁶ Pa m ³ /s | |
| -20– +40°C | |
| Water | |
| H1 | |
| 3 l | |
| 79 dB(A) | |
| 74 dB(A) | |
| 11 kW | 18.5 kW |
| 11 kW | 18.5 kW |
| 400/690 V | |
| – | |
| 3x PTC | |
| IP 55 | |

| Okta 5400 ATEX | Okta 8100 ATEX |
|------------------------------|------------------------------|
| – | – |
| PP V60 393 100 ⁴⁾ | PP V61 393 100 ⁴⁾ |

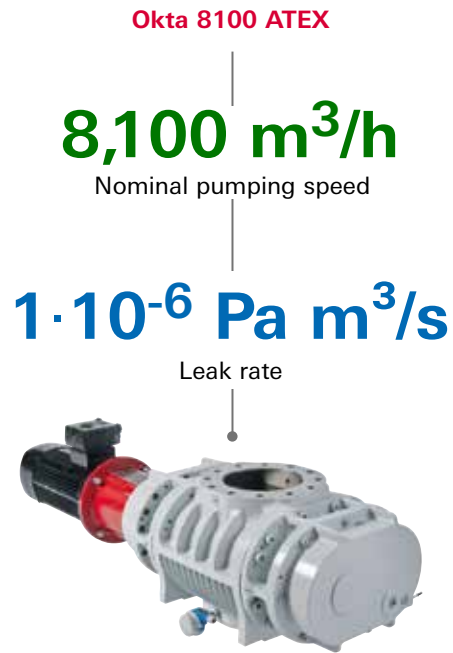

Your Success. Our Passion.

We give our best for you every day –
worldwide!

Are you looking for an
optimal vacuum solution?
Please contact us:

Pfeiffer Vacuum GmbH
Germany
Phone +49 6441 802-0



Errors excepted. All data subject to change without prior notice. PW 0042 PEN (May 2022/PoD)

Follow us on social media
#pfeiffervacuum



www.pfeiffer-vacuum.com

PFEIFFER  **VACUUM**